

Clearance Compliance Report

**For “M/s. NIRA BHIMA SAHAKARI SAKHAR
KARKHANA LTD; SHAHAJINAGAR”**



**M/s.Nira Bhima Sahakari Sakhar Karkhana Ltd.,
At Shahajinagar, Post-Redni, Taluka-Indapur,
Dist-Pune- 413114**

Prepared by

PRAGMATIC BIO AND ENVIRO

Scheme No-2/1, Sector No-25, Bhel Chowk, Opp.
Dhanvantari Hospital, Sindhu Nagar, Nigadi, Pune-44
Maharashtra, India

Email id- pragenviro@gmail.com

Contact No-758078954

Nira Bhima Sahakari Sakhar Karkhana Ltd.

Shahajinagar, Tal. Indapur, Dist. Pune.

Founder:

Hon. Shri. Harshwardhan Shahajirao Patil

Ex. Minister: Co-Operation & Parliamentary Affairs

Bawada: Tel: 02111-275501, 275100

Ref No.: NIRA-BHIMA/ENV/R/249/2019-20

Date: 27/5/2019

To,
The Additional Director (S),
Ministry of Environment, Forest and Climate Change
Regional Office (WCZ), Ground Floor,
East Wing, New Secretariat Building,
Civil Line, Nagpur, Maharashtra-440001

Sub: Half Yearly Post Environment Clearance Compliance Report for "Nira Bhima Sahakari Sakhar Karkhana Ltd" at Shahajinagar, Post- Redni, Tal-Indapur, Dist- Pune, Maharashtra.

Ref: Environmental Clearance Letter No. SEAC-2012/CR-177/TC-2.

Respected Sir,

We are submitting herewith the Half Yearly Post Environment Clearance Compliance Reports **(December 2018 to May 2019)** for Nira Bhima Sahakari Sakhar Karkhana Ltd" at Shahajinagar, Post- Redni, Tal-Indapur, Dist- Pune, Maharashtra. EC accorded by Department of Environment, Government of Maharashtra, vide its Letter No. SEAC-2012/CR-177/TC-2, dated 21st January 2014.

Thanking you,

Yours Faithfully,

For M/s. Nira Bhima Sahakari Sakhar Karkhana Ltd. (NBSSKL)

Authorized Signature
[Mr. D. V. Mane-M.D.]

MANAGING DIRECTOR
Nira Bhima S.S.K.Ltd., Shahajinagar
Tal-indapur, Dist-Pune

Copy to:-

1. Regional office Maharashtra Pollution Control Board, Pune.
2. The Member Secretary, Maharashtra Pollution Control Board, Mumbai
3. The Member Secretary, State Level Expert Appraisal Committee-(SEAC)

LIST OF ANNEXURES

Sr.No.	Particulars	Annexure No.
1	Project Details/Data Sheet	I
2	Salient Features of The Project	II
3	Environment Management Plan	III
4	Cost Of Environment Management Plan	IV
5	Compliance of Environment Clearance Conditions	V
6	Copy of Consent to Establish and consent to Operate	VI
7	Environmental Monitoring Reports	VII
8	Copy Of Environment Clearance	VIII

PART – I, Data Sheets
For Nira Bhima Sahakari Sakhar Karkhana Ltd.,
At Shahajinagar, Post-Redni, tal-Indapur,
District Pune, Maharashtra

MONITORING THE IMPLEMENTATION OF ENVIRONMENTAL SAFEGUARDS

PART – I -DATA SHEET

PERIOD OF COMPLIANCE REPORT- [DECEMBER 2018 TO MAY 2019]

1.	Project type: River –Valley/ Mining/ Industry/ Thermal/ Nuclear/ other (specify)	Industry
2.	Name of the Project	18 MW Bagasse Based Co- generation Power Plant by M/s. Nira Bhima Sahakari Sakhar Karkhana Ltd., (NBSSKL)
3.	Environment Clearance Letter (s)/OM No. and date	SEAC-2012/CR-177/TC-2dtd. 21 st January 2014
4.	Location: (a) District (s) (b) State (s) (c) Location Latitude/ Longitude	Pune Maharashtra 17°59'29.94"Nand 74°56'42.45"E
5.	(a) Address for correspondence	M/s. Nira Bhima Sahakari Sakhar Kharkhana Ltd., Shahajinagar, Post-Redni, Tal-Indapur, Dist-Pune – 413114
	(b) Address of Executive Project Engineer/ Manager (with pin code / Fax)	Mr. D.V. Mane- (Managing Director) M/s. Nira Bhima Sahakari Sakhar Karkhana Ltd., At Shahajinagar, Post-Redni, Tal-Indapur, Dist-Pune, Maharashtra-413114 Telephone No.: 02111 – 275501/275100 Mob. No- 9146003002 Email id: nirabhima@rediffmail.com
6.	Salient Features	
	(a) Of the project	Please Refer Annexure – II
	(b) Of Environmental Management Plans	Please Refer Annexure – III
7.	Breakup of the project area	Total Plot Area – 100 (Acre) Built-up Area- 11 (Acre)
	(a) Submergence area: forest & non forest	Not Applicable
	(b) Others	Not Applicable

8.	Breakup of the project affected population with enumeration of those losing houses /dwelling units only, agricultural land only, both dwelling units & agricultural land & landlesslabourers /artisan.	There is no displacement of population due to project hence not applicable.
	(a) SC, ST /Adivasis	Not Applicable since there is no displacement of population
	(b) Others (Please indicate whether these figures are based on any scientific and systematic survey carried out or only provisional figures, if a survey is carried out give details and years of survey)	Not Applicable since there is no displacement of population
9.	Financial details	
	(a) Project cost as originally planned and sub-subsequent revised estimates and the year of price reference.	87.817 Cr
	(b) Allocation made for environmental management plans with item wise and year wise break-up.	Please refer annexure IV
	(c) Benefit cost ratio/Internal rate of Return and the year of assessment	-----
	(d) Whether (c) include the cost of environmental management as shown in the above.	Yes
	(e) Actual expenditure incurred on the project so far	0.00 Cr
	(f) Actual expenditure incurred on the environmental management plans so far	17.80 Lacs
10.	Forest land requirement.	No Forest land required for project

	(a) The status of approval for diversion of forest land for non-forestry use	Not applicable	
	(b) The status of clearing felling	Not applicable	
	(c) The status of compensatory a forestation, if any	Not applicable	
	(d) Comments on the viability & sustainability of compensatory a forestation Programme in the light of actual field experience so far	Not applicable	
11.	The status of clear felling in non-forest areas (such as submergence area of reservoir, approach roads), if any with quantitative information	Nil	
12.	Present Status of construction. (Actual &/or planned)	Planned	Actual
		18 MW Bagasse Based Co-generation Power Plant	Work is Completed
	(a) Date of Commencement (Actual &/or planned)	14th August 2013	
	(b) Date of completion (Actual &/or planned)	28th November 2014	
13.	Reason for the delay if the project is yet to start.	Not Applicable	
14.	Dates of Site Visits		
	(a) The dates on which the project was monitored by the regional office on previous occasions, if any.	Yes, MPCB officer visited the site.	
	(b) Date of site visit for this Environment monitoring report	May 2019	

For M/s. Nira Bhima Sahakari Sakhar Karkhana Ltd., (NBSSKL)

Authorized Signatory
[Mr. D. V. Mane-M.D.]

Salient features of the Project

Salient Features of the Project

Name of the Project	“Nira Bhima Sahakari Sakhar Karkhana Ltd.” (NBSSKL)
Project Site	The Project Site is located near Shahajinagar, Post-Redni, Dist-Pune, Maharashtra
Installed Capacity	18 MW
Total Plot Area	100 (Acre)
Total Built- up Area	11 (Acre)
Availability of Land	411074 Sq.M.
Quantity of Water requirement	Season (160 Days) : 893 CMD Off Season (69 Days) 1009 CMD
Source of Water	Bhima River (8.5 KM)
Estimated project cost	8187.70 Lakhs
Nearest Town	Indapur is at a distance of 16 KM
Nearest railway station	Baramati R.S. is at a distance of 50 KM
Nearest Airport	Nearest Airport is at solapur at a distance of 112 Km

Google Image



Environmental Management Plan (EMP)

Cost of Environmental Management Plan (EMP)

Cost of Environmental Management Plan

Sr. No.	Particulars	Capital Cost (INR) in Lacs	Recurring Cost (INR/Year) in Lacs
1.	Air pollution Control System	200.00	12.00
2.	Water Pollution Control Systems (E.T.P)	--	15.00
3.	Noise Pollution Control	20.00	2.00
4.	Green Belt Development/Maintenances	25.00	2.50
5.	Environmental Monitoring/Environmental Management	25.00	5.00
6.	Occupational Health and Safety	10.00	5.00
Total		280.00	29.00

COMPLIANCE REPORT
For
“Nira Bhima Sahakari Sakhar Karkhana Ltd”
At Shahajinagar, Post-Redni
Tal-Indapur, Dist-Pune

EC No.	SEAC- 2012/CR-177/TC-2
Project Name	Nira Bhima Sahakari Sakhar Karkhana Ltd.
Location	Shahajinagar, Post-Redni, Tal-Indapur, Dist. Pune, Maharashtra- 413114
	PERIOD OF COMPLIANCE REPORT:FROM JUNE 2018 TO NOVEMBER 2018 COMPLIANCE TO THE STIPULATED CONDITIONS OF EC DATED- 21/01/2014
Part – A Specific Conditions	
Particulars	Status
No additional land shall be used/acquired for any activity of the project without obtaining proper permission	No additional land will used
For Controlling fugitive natural dust, regular sprinkling of water & wind shields at appropriate distances in vulnerable areas of the plant shall be ensured	Yes. It is being practiced.
Regular monitoring of the air quality, including SPM & SO ₂ levels both in work zone and ambient air shall be carried out in an around the power plant and records shall be maintained. The location of monitoring stations and frequency of monitoring shall be decided in consultation with Maharastra Pollution control Board (MPCB) & Submit report accordingly	We are monitoring PM-10, PM 2.5, SO _x , NO _x and CO in ambient air as prescribed in the NAAQS, dated- 14/11/2018. Refer Annexure No.VII
Necessary arrangement shall be made to adequate safety and ventilation arrangement in furnace area	Proper Ventilation and safety will be provided.
Proper Housekeeping programmes shall be implemented	We take good care of the premises by practicing proper house keeping practices.
In the event of the failure of any pollution control system adopted by the unit, the unit shall be immediately put out of operation and shall not be restarted until the desired efficiency has been achieve	Noted.
A Stack of adequate height based on DG set capacity shall be provided for control and dispersion of pollutant from DG Set. (If Applicable)	Noted.
A detailed scheme for rainwater harvesting shall be prepared and implemented to recharge ground water.	Entire rooftop in township is covered under rainwater harvesting wherein the rooftop water is collected and channeled into different injection wells, pond and check dams constructed in the

	township.
Arrangement shall be made that waste water and storm water do not get mixed	We will maintain the waste water and Storm water separately.
Periodic monitoring of ground water shall be undertaken and result analyzed to ascertain any change in the quality of water. Results shall be regularly submitted to the Maharashtra Pollution Control Board.	The ground water level and its quality is monitored on regular basis. Analysis Reports is attached herewith dated- 14/11/2018. Refer Annexure No. VII
Leq of Noise level shall be maintained as per standards. For People working in the high noise area, requisite personal protective equipments like ear plugs etc. Shall be provided.	Regularly carried out Noise Monitoring at the site, report of the same is attached herewith dated- 14/11/2018. Refer Annexure No. VII
The overall noise levels in and around the plant are shall be kept well within the standards by providing noise control measures including acoustic hoods, silencers, enclosures, etc. On all sources of noise generation. The ambient noise level shall conform to the standards prescribed under Environment (Protection) Act, 1986 Rules, 1989.	All necessary noise control measures including acoustic hoods, silencers, enclosures etc. on all sources of noise generation are in place and properly maintained. Workplace noise level survey is conducted on regular basis to identify areas with high noise levels. Corrective /preventive actions are taken if the noise levels exceed the permissible limits as stipulated in the EP/Factories Act. Workers employed in High Noise Area are provided with proper PPEs and their exposure to noise is controlled within the permissible limits. Periodic audiometric tests of the workmen employed in High Noise Area is also conducted as part of Workers' Health Surveillance Program. Ambient Noise level is monitored regularly and is controlled within the stipulated limit.
Green belt shall be developed & maintained around the plant periphery. Green belt development shall be carried out considering CPCB guidelines including selection of plant species and in consultation with the local DFO/Agriculture Dept.	Development of Green Belt has been initiated Considering CPCB / MPCB guidelines. Around 300 saplings have been planted inside the premises.
Adequate safety measures shall be provided to limit the risk zone within the plant boundary, in case of accident. Leak detection shall be installed at Strategic places for early detection.	Adequate safety measures are taken to control the hazard and keep it below the acceptable limit. Leak detection systems are installed and monitored regularly.
Occupational health surveillance of the workers shall be done on a regular basis and record maintained as per factories act	We will take good care regarding the health of the workers in the site.
The Company shall make the arrangement for protection of possible fire hazards during manufacturing process in material handling	Fire hydrant and sprinkler system is provided and maintained to ensure smooth operation at all times.
The Project authorities must strictly comply with the rules and regulations with regard to handling and disposal of hazardous waste in accordance with the	Consent to Establish is obtained from MPCB vide No-Format 1.0/BO/JD/(WPC)/EICNo.PN-16784-13/E/CAC-6801 Dated:- 14/08/2013 Attached herewith as an

<p>hazardous waste (Management and Handling) Rules, 2003 (amended). Authorization from the MPCB shall be obtained for collections/treatment/storage/disposal of hazardous waste</p>	<p>Annexure-VI</p>
<p>The company shall undertake following waste Minimization Measures:</p> <ul style="list-style-type: none"> • Metering of quantities of active ingredients to minimize waste • Reuse of by- products from the process as raw materials or as raw material substitutes in other process • Maximizing Recoveries. • Use of automated material transfer system to minimize spillage. 	<p>Noted and Complied</p>
<p>Regular mock drills for the on-site emergency management plan shall be carried out. Implementation of changes/improvements required, if any in the on-site management plan shall be ensured.</p>	<p>Mock drills are conducted periodically. Regular up gradation in the emergency plan is done. We have also successfully carried out off site mock-drill in coordination with various civil authorities</p>
<p>A separate environment management cell with qualified staff shall be setup for implementation of the stipulated environmental safeguards.</p>	<p>A separate Environment Management Cell is already set up under the control of Plant Head in order to oversee effective implementation of environment protection measures and to monitor the routine environmental performance within the premises.</p>
<p>Transportation of ash will be through closed containers and all measures should be taken to prevent spilling of the ash.</p>	<p>Noted and complied</p>
<p>Separate silos will be provided for collecting and storing bottom ash and fly ash</p>	<p>Noted and complied</p>
<p>Separate funds shall be allocated for implementation of environmental protection measures/EMP along with item-wise breaks-up. These cost shall be included as part of the project cost. The funds earmarked for the environmental protection measures shall not be diverted for other purpose and year-wise expenditure should reported to the MPCB & this department</p>	<p>Provision made for separate funds for implementation of environmental protection measures/ EMP and same has been included in project cost. All the reporting is done in timely manner to concerned authorities.</p>
<p>The project Management shall advertise at least in two local newspapers widely circulated in the region around the project, one of which shall be in the Marathi language of the local concerned within seven days of issue of this letter, informing that the project has been accorded environmental clearance and copies of clearance letter are available with Maharashtra Pollution Control Board and</p>	<p>Noted.</p>

may also be seen at website at http://ec.maharashtra.gov.in	
Project Management should submit half yearly compliance reports in respect of the stipulated prior environment clearance terms and conditions in hard & Soft Copies to the MPCB & this department, on 1st June&1st December of each calendar year.	Complied. Six monthly Compliance report are being submitted regularly.
A copy of Clearance letter shall be sent by proponent to the concerned Municipal corporation and the local NGO, if any, from whom suggestions/representations, if any were received while processing the proposal. The clearance letter shall also be put on the website of the company by the proponent.	Noted and complied
The proponent shall upload the status of compliance of the stipulated EC Conditions, including results of monitored data on their website and shall update the same periodically. It shall simultaneously be sent to the regional office of MoEF, the respective zonal office of CPCB & the SPCB. The criteria pollutants levels namely. SPM, RSPM, SO₂, Nox (ambient level as well as stack emissions) or critical sectoral parameters, indicated for the project shall be monitored and displayed at a convenient location near the main gate of the company in the public domain.	Six monthly compliance reports in respect of Post Environment Clearance Monitoring (Rule 10 of EIA Notification, 2006, dated 14.09.2006) are timely submitted in hard and soft copies to the concerned regulatory authorities.
The Project proponent shall also submit six monthly reports on the status of compliance of stipulated EC Conditions including results of monitored data (both in hard copies as well as by email) to the respective zonal office of CPCB & the SPCB.	Six monthly reports along with the monitored data are regularly sent to the concerned authorities in hard and soft copies.
The environmental statement for each financial year ending 31st March in Form-V as is mandated to be submitted by the project proponent to the concerned State Pollution Control Board as prescribed under the Environment (Protection) Rules. 1986, as amended subsequently, shall also be put on the website of the company along with the status of compliance of EC conditions and shall also be sent to the respective Regional Offices of MoEF by e-mail.	Annual Environment Statement is regularly sent to the MPCB, MoEF Nagpur and CPCB. In addition, a copy of the statement is also uploaded on the company's website.
The environmental clearance is being issued without prejudice to the court case pending in the court of law and it does not mean that project proponent has not violated any environmental laws in the past	Not Applicable, as no pending case in the court of Law.

<p>and whatever decision of the Hon'ble court will be binding on the project proponent. Hence this clearance does not give immunity to the project proponent in the case filed against him</p>	
<p>The environmental clearance is being issued without prejudice to the action initiated under EP Act or any court case pending in the court of law and it does not mean that project proponent has not violated any environmental laws in the past and whatever decision under EP Act or of the Hon'ble court will be binding on the project proponent. Hence this clearance does not give immunity to the project proponent in the case filed against him, if any or action initiated under EP Act.</p>	Noted
<p>The Environment department reserves the right to add any stringent condition or to revoke the clearance if conditions stipulated are not implemented to the satisfaction of the department or for that matter, for any other administrative reason.</p>	Noted
<p>Validity of Environment Clearance: The environmental clearance accorded shall be valid for a period of 5 years</p>	Noted
<p>In case of any deviation or alteration in the project proposed from those submitted to this department for clearance, a fresh reference should be made to the department to assess the adequacy of the condition(s) imposed and to incorporate additional environmental protection measures required, if any.</p>	Noted
<p>The above stipulations would be enforced among others under the Water (Prevention and Control of Pollution) Act, 1974, the Air (Prevention and Control of Pollution) Act, 1981. The Environment (Protection) Act, 1986 and rules there under, Hazardous Wastes (Management and Handling) Rules, 1989 and its amendments, the public Liability Insurance Act, 1991 and its amendments.</p>	Noted
<p>Any appeal against this environmental clearance shall lie with the National Green Tribunal , Van VigyanBhawan, Sec- 5, R.K. Puram, New Dehli — 110 022, if preferred. Within 30 days as prescribed under Section 16 of the National Green Tribunal Act, 2010.</p>	Noted

	Environmental Impact Assessment Report of 18MW Co-Gen Power Plant by NBSSKL at Shahajinagar Post Redni, Dist Pune EME/CS/EIA- NBSSKL-IND/2012-13/108:R00dt.:28/11/2012	EIA Report (R-00)
---	--	--------------------------

CHAPTER 9

ENVIRONMENTAL MANAGEMENT PLAN

9.1 INTRODUCTION

In view of the global concept of sustainable development, Environment Management is a crucial segment of Industrial Management. Apart from the social obligation, the industries are required to meet a series of statutory norms laid by Government bodies. Better environment management means less waste generation, better resources management leading to cost savings. Further, it gives a better public image. Therefore, preparation of Environmental Management Plan is a must to fulfill bifocal aspect of the statutory compliance as well as that of social concern. The objective of Environment Management Plan (EMP) is to conserve resources, minimize waste generation, treatment of wastes and protect natural properties. Environmental Management Plan (EMP) has been prepared on the basis of existing environmental status of the project location and the expected impacts of the project activities on environment

The management of the M/s. NBSSKL will take all the necessary steps to control and mitigate the environmental pollution in the designing stage of the project. While implementing the project M/s. NBSSKL will follow guidelines specified by CPCB under the Corporate Responsibility for Environmental Protection (CREP) for power plants. The EMP task will likely be administered by the “Health, Safety and Environment (HSE) Department”, who will have the authority where necessary to “stop the job” if an environmentally detrimental activity is being conducted.

The EMP operation/implementation will be the responsibility of the “HSE Officer”, who will be coordinating, arranging the collection and reporting of the results of all emissions, ambient air quality, noise and water quality monitoring.

Water needs of proposed Sugar Complex may be reasonably low, but generally this resource is declining. Thus, on one hand one should use it less and on the other the source should not be left polluted for others. Air environment needs to be continuously managed, because man needs inhalation every moment, so also is Flora and Fauna dependent on it. The biological aspects, soil and ground water are all interdependent. Thus, there is a need of proper environmental management and a conscious plan for it.

	Environmental Impact Assessment Report of 18MW Co-Gen Power Plant by NBSSKL at Shahajinagar Post Redni, Dist Pune EME/CS/EIA- NBSSKL-IND/2012-13/108:R00dt.:28/11/2012	EIA Report (R-00)
---	---	--------------------------

It is mandatory for the industry to submit Environmental Statement to State Pollution Control Board as per Environment (Protection), Amendment Rule, 1993 for the previous financial year ending 31st March on or before 30th September every year (Financial environmental statement FY 2011-12 attached as an **Annexure- 14**).

To draw a rigid EMP is especially important because, India has to support 16.1% of the world's population only on 2.3 % of the global area with 0.4% of energy reserve. This point of Low Energy Reserve is especially taken note by the Project Proponents. In this respect efforts are oriented towards:

- Bagasse is used for energy
- Ash will be used for Biocomposting to produce manure
- Treated effluent will be used for green belt development & agricultural purposes.

9.2 OBJECTIVES OF ENVIRONMENTAL MANAGEMENT PLAN

- To define the components of environmental management.
- To prepare an environmental hierarchy.
- To prepare a checklist for statutory compliance.
- To prepare environmental organization.
- To prepare a schedule for monitoring and compliance.

9.3 CHECKLIST OF STATUTORY OBLIGATIONS

There are a number of environmental statutes required to be attained by the industries. NBSSKL shall obey the provisions of all relevant Acts, Rules, Notifications and Orders.

The checklist of these obligations, which facilitates the obedience of the laws of land are given below :

- Water (Prevention and Control of Pollution) Act, 1974;
- Water (Prevention and Control of Pollution) Cess Act, 1977;
- Air (Prevention and Control of Pollution) Act, 1981;
- Environment (Protection) Act, 1986;
- Environment (Protection) Rules, 1986;
- Hazardous Waste (Management and Handling) Rules 2003;
- EIA Notification'2006.

	Environmental Impact Assessment Report of 18MW Co-Gen Power Plant by NBSSKL at Shahajinagar Post Redni, Dist Pune EME/CS/EIA- NBSSKL-IND/2012-13/108:R00dt.:28/11/2012	EIA Report (R-00)
---	--	--------------------------

9.4 INSTITUTIONAL ARRANGEMENTS FOR ENVIRONMENT PROTECTION & CONSERVATION

Environmental Management Cell will be established, which will be supervised and controlled by an independent Plant Manager supported by a team of technically qualified personnel apart from other operating staff. Organization structure of the Environment Management Cell is presented in **Figure 9.1**.

It will be the responsibility of this Cell to supervise the monitoring of environmental attributes viz. ambient air quality, water and effluent quality, noise level etc either departmentally or by appointing external agencies wherever necessary. In case the monitored results of environmental contaminants are found to exceed the standard limits, the Environmental Management Cell will suggest remedial measures and get them implemented.

The functions of Environmental Management Cell will be as follows:

- Obtaining Consent Order from the Maharashtra Pollution Control Board.
- Environmental monitoring.
- Analysis of environmental data, preparation and submission of reports to statutory authorities, Corporate Centre etc.
- Co-ordination with statutory bodies, functional groups of the station, head office etc.
- Interactions for evolving and implementation of modification programs to improve the availability/ efficiency of pollution control devices / systems.
- Conducting Environmental Appraisal (Internal) and Environmental Audit.

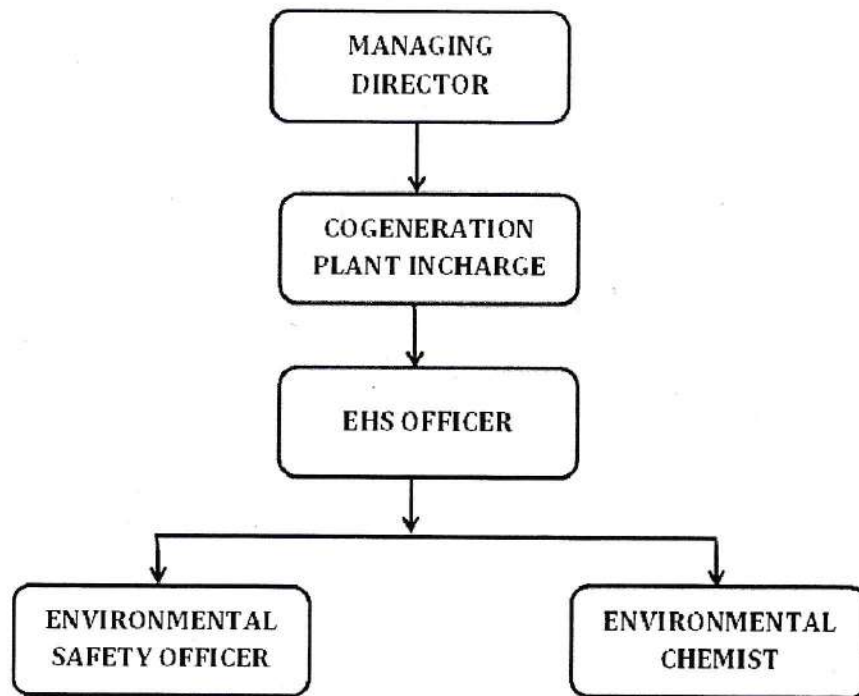



Figure 9.1: Environment Management Cell

Environment management plan will apply the construction as well as operation phase of the plant to mitigate negative impacts due to proposed activity

9.5 CONSTRUCTION PHASE ENVIRONMENT MANAGEMENT

The construction activities of the proposed unit will increase in dust concentrations and fugitive emission due to vehicles movement. Frequent water sprinkling in the vicinity of the construction sites will be undertaken. The following control measures are recommended to mitigate the probable adverse impacts:

- During construction phase M/s NBSSKL will be taken care to provide all necessary facilities to construction workers such as water supply, sanitary facilities, temporary housing, sewage treatment facilities, drainage facilities and domestic fuels
- Vehicles transporting loose construction material (clay, sand etc.) to be covered with tarpaulins.
- During construction periods with abnormal wind speeds, in particular during dry weather conditions, workers on the construction site should be provided with adequate inhalation and eyes protection gears. In case particulates in air hamper a clear view over

	Environmental Impact Assessment Report of 18MW Co-Gen Power Plant by NBSSKL at Shahajinagar Post Redni, Dist Pune EME/CS/EIA- NBSSKL-IND/2012-13/108:R00dt.:28/11/2012	EIA Report (R-00)
---	---	--------------------------

the site completely, so that safety is impaired, the construction should be interrupted until weather conditions improve.

- Necessary care will be taken as per the safety norms for the storage of the petroleum products (Diesel, Petrol, Kerosene etc).
- It will be ensured that both gasoline and diesel powered vehicles are properly maintained to comply to the exhaust emission standards.
- Contractor will supervise the safe working of their employees.
- Barricades and fences are provided around the construction area personnel protective equipments e.g. safety helmet, goggles, gumshoes, etc. will be provided to the workers.
- Accidental spill of oils from construction equipment and storage sites will be prevented.
- Though the effect of noise on the nearby inhabitants due to construction activity will be negligible, noise prone activities will be restricted to the day time.
- As soon as construction is over, surplus of excavated material will be utilized to fill up low lying areas and all surfaces will be reinstated.
- Routing and scheduling construction trucks to reduce delays to traffic during peak travel times would reduce secondary air quality impacts caused by a reduction in traffic speeds while waiting for construction trucks
- M/s NBSSKL will give preference to local eligible people through both direct and indirect employment.
- Tree plantation will be undertaken during the construction phase for strengthen the existing green belt so that air pollution will be nullify in operation phase of the project.
- Educational needs of the region will be improved by encouraging the workers to allow their children to attend school.

9.6 OPERATIONAL PHASE ENVIRONMENT MANAGEMENT

9.6.1 Air Environment

The major pollutants from existing & proposed activity are PM₁₀ & PM_{2.5}, Sulphur Dioxide and Oxides of Nitrogen.

9.6.1.1. Stack Emissions

The following measures will be adopted for the control of emissions from the stacks of the proposed unit.

	Environmental Impact Assessment Report of 18MW Co-Gen Power Plant by NBSSKL at Shahajinagar Post Redni, Dist Pune EME/CS/EIA- NBSSKL-IND/2012-13/108:R00dt.:28/11/2012	EIA Report (R-00)
---	--	--------------------------

- The height of the stack will be 75 m for proposed 66 TPH boiler with single chimney as per CPCB Norms .
- Suitably designed ESP with efficiency of 99.9 % will be placed downstream of the stack which will separate out the incoming dust in flue gas so as to maintain the emissions PM10 & PM2.5 (50 mg/Nm³) at the outlet of the stack.
- Stack emissions will be regularly monitored by NBSSKL/external agencies on periodic basis to check the efficiency of air polluting control devices and necessary action.

Table 9.1: CPCB Standards for Stack Height

Generation Capacity	Pollutant	Emission limit
210 MW or more	Particulate matter	150 mg/Nm ³
Less than 210 MW	Particulate matter	350 mg/Nm ³
Depending upon the requirement of local situation, such as protected area, the State PCB and other implementing agencies under the Environment (Protection) Act, 1986, may prescribe a limit of 150 mg/Nm ³ , irrespective of generation capacity of the plant.		
Stack height /limits		
Generation capacity	Stack Height (meters)	
500 MW and above	275	
200 MW/210 MW & above to less than 500 MW	220	
Less than 200 MW/210 MW	$H=14(Q)^{0.3}$ where Q is emission rate of SO ₂ in kg/hr, and H is stack height in meters	
<i>Source: CPCB Environmental Regulations for Thermal Power Plants</i>		

- Based on the above the stack height will be 76 m for proposed unit in order to restrict the GLC of SO₂ and NO_x within the prescribed limit of CPCB (AAQ standard for SO₂ and NO_x is <80 µg/m³ for 24 hourly basis).
- The advantage of the grate type boiler where the combustion temperature is in the range 850-900⁰c resulting in lower NO_x emissions.

	Environmental Impact Assessment Report of 18MW Co-Gen Power Plant by NBSSKL at Shahajinagar Post Redni, Dist Pune EME/CS/EIA- NBSSKL-IND/2012-13/108:R00dt.:28/11/2012	EIA Report (R-00)
---	--	--------------------------

- To control of the airborne fugitive emissions from the ash handling area will be achieved through regular water sprinkling in this area.
- Avenue plantation and green belt development will be undertaken in the operation phase.

9.6.1.2. Fugitive Emission Management

The following measures will be adopted to control the fugitive emissions:

- The dust generated from vehicular traffic during operation phase will be suppressed by providing adequate water spray systems.
- All vehicles and their exhausts will be well maintained and will be regularly monitored for emission generated from the vehicle exhaust;
- Provide wheel washers for vehicles to remove particulate matter that would be carried offsite by vehicles that would decrease deposition of particulate matter on area roads and subsequent entrainment from those roads.
- To control of the airborne fugitive emissions from the ash handling area will be achieved through regular water sprinkling in this area.
- The green belt development at ash handling areas will be undertaken.
- Avenue plantation and green belt development will be undertaken in the operation phase.

9.6.1.3. Stack Gas Monitoring

The emissions from the stack will be monitored continuously for exit concentration of the suspended particulate matter, SO₂ µg/m³ and NO_x µg/m³. Sampling ports will be provided in the stacks as per CPCB guidelines. If the concentration of these pollutants exceeds the limits, necessary control measures will be taken.

9.6.2 Noise Environment

The design features provided to ensure low noise levels are as given below:

- All rotating items will be well lubricated and provided with enclosures as far as possible to reduce noise transmission. Vibration isolators will be provided to reduce vibration and noise wherever possible

	Environmental Impact Assessment Report of 18MW Co-Gen Power Plant by NBSSKL at Shahajinagar Post Redni, Dist Pune EME/CS/EIA- NBSSKL-IND/2012-13/108:R00dt.:28/11/2012	EIA Report (R-00)
---	---	--------------------------

- Manufacturers and suppliers of machine/equipment like cane handling equipments i.e. Belt Conveyor, Compressors, STG, Turbine and generators will be manufactured as per OSHA/ MoEF guidelines.
- The insulation will be provided to reduce noise.
- The personnel safety such as ear muffs, ear plugs and industrial helmets will also act as a noise reducers will be provided workers.
- Layouts of equipment foundations and structures will be designed keeping in view the requirement of noise abatement;
- Central control room(s) provided for operation and supervision of plant and equipment will be air-conditioned, glass fiber insulated frames which will help in reducing noise levels. Necessary enclosures will also be provided on the working platforms/areas to reduce the noise levels ;
- The workers working in the high noise areas like compressor houses, crushers, crystallizer, sulphator, blowers, generators, feed pumps, steam generation plant and turbo generator area will be provided with ear muffs/ear plugs
- Acoustic laggings and silencers will be provided in equipment wherever necessary. The compressed air station will be provided with suction side silencers. Ventilation fans will be installed in enclosed premises
- Supply ducts and grills on the ventilation and air conditioning system will be suitably sized for minimum noise level
- The silencers and mufflers of the individual machines will be regularly checked
- The noise level will not exceed the permissible limit 75 dB (A) during the day time 70 dB (A) night time within the plant premises. Green belt around the plant area will reduce the noise level further.
- Occupational Health & Safety (OHSAS) System for evaluation of exposure of noise pollution on the associated staff and comparing it with permissible exposure and subsequently taking corrective actions will be developed.
- The adoption of the above measures, it is anticipated that noise levels will be maintained in 45-50 dB (A) range at the boundary of the plant premises. Earth mounds and plantations on the periphery of the plant would further attenuate noise level.

9.6.3 Ash Evacuation System

The ash handling system envisaged for the Cogeneration power project is of two types:

1. Submerged belt conveyor system for grate ash
2. Mechanical ash handling system for fly ash

The ash generated from the boiler shall be collected separately and taken to a common ash silo system for disposal. The total generated ash during season and offseason operation are presented **Table 9.2**

Bagasse based ash removed from the grate is approximately 40% and the fly ash quantity is approximately 60% from the ESP.

Table 9.2: Ash Generation

Sr No.	Fuel	Fuel Feeding		% of Ash	Ash Generation					
		Season – 160 Days			Off-Season – 72 Days		Season (160 Days)		Off-season (69Days)	
		Season (18MW)	Off-season (12 MW)		Bottom Ash	Fly Ash	Bottom Ash	Fly Ash		
1	Bagasse	152564 MT	32493 TPH	2	1221MT	1830MT	260 MT	390MT		
Total					1221 MT	1830MT	260 MT	390 MT		

9.6.3.1. Bottom Ash Handling (BAH) Evacuation System

Bagasse based bottom ash during season i.e 1221MT and during off-season i.e.260 MT shall be collected in water impounded, refractory lined, triple 'v' type bottom ash silo having capacity 100m³. The ash received in the grate discharge hoppers will be around 500⁰C, with ash lumps of size 200 mm maximum. The ash from ash riddling hopper will be dry and powdery in nature and occasionally with hot solids. Generated ash shall be used for bio-composting along with pressmud (generated from sugar factory) because it contains high percentage of potash.

	Environmental Impact Assessment Report of 18MW Co-Gen Power Plant by NBSSKL at Shahajinagar Post Redni, Dist Pune EME/CS/EIA- NBSSKL-IND/2012-13/108:R00dt.:28/11/2012	EIA Report (R-00)
---	---	--------------------------

9.6.3.2. Fly Ash Handling System

- The fly ash (as collected in ESP hoppers, APH hopper and duct hoppers) generated during season operation will be 1830 MT. & during off-season 390 MT. A separate system will be designed to collect fly ash in dry form in RCC silo using vacuum cum pressure pneumatic system. From the silos, fly ash could be dispatched to nearest local users in trucks.
- The fly ash conveying air will be vented to the atmosphere through vent bag filter. Bagasse based ash mixed with press mud and used as manure in surrounding agro-field. Separate system will designed for bio-composting.

9.6.3.3. Ash Utilization/Management System

As per the MoEF notification dated on 3rd April 2007 S.O.513 (E) on fly ash utilization, as per the item (2) under the responsibility of cogen-power plant fly ash shall not at any time store more than three months in their storage/ ash pond.

Fly ash generated from the cogen -power plant will be commercially utilized, to the extent possible, in one or more of the following industries: (i) cement, (ii) brick, (iii) fly ash, (iv) road making and paving, (v) agriculture(soil conditioner), (vi) back filling and (vii) any other industry that is technically feasible. Apart from these uses, fly ash can be used for the construction of ash- pond dyke, reclamation of low-lying areas.

The following strategies will be adopted to ensure 100% fly ash utilization

- Bagasse based ash mixed with press mud and used as manure in surrounding agro-field. Existing system will be used for preparation of manure.
- Bagasse based ash contain high percentage of potash it is good nutrient for plant growth in agro-field. So that 100% utilization plan for bagasse ash will be planned.
- Basic technology, as well as initial expert advice for using fly ash in making bricks and cement blocks, will be provided to local brick and cement block makers free of charge.
- The state government will be requested to provide certain financial incentives to brick and cement block makers, and to ensure the use of fly ash building materials in public works projects to the fullest possible extent. The state government can be requested to provide valuable assistance by creating ash depots under its auspices.



9.6.5 Water Environment

9.6.5.1 Wastewater Management

The total fresh water requirement for the proposed activity will be 893 m³/day during season and 1003m³/day during off-season and waste water generation will be 146 m³/day during season and 144 m³/day during off-season. The continuous efforts will be made to reduce the water consumption and thereby reduce wastewater generation. Flow meters will be installed on all major water inlets and the flow rates will be continuously monitored. Periodic water audits will be conducted to explore the possibilities of minimizing water consumption.

The wastewater generated from the different units such as cooling tower blow down, boiler blow down, DM plant, domestic waste water of proposed activity shall be treated in existing ETP having capacity 700 m³/day. NBSSKL has already modernized existing ETP for effective treatment. (Details ETP along with treated waste water quality results attached as an **Annexure15**).

9.6.5.2. Effluent from water treatment plant

The water treatment plant will be based on conventional water treatment system; the requirement of the chemicals will be same as that of a conventional demineralization plant. The acid and alkali effluents generated during the process of the ion-exchangers would be drained into an epoxy lined underground neutralizing pit. Generally these effluents are self neutralizing. However, provisions will be made such that the effluents will be neutralized by addition of either acid or alkali to achieve the required pH of about 7.0. The effluent will then be pumped into the effluent treatment ponds, which form part of the effluent disposal system.

The effluent from the neutralizing pit will be pumped by 2 x 100% capacity pumps to the Effluent Treatment Plant (ETP).

The WTP discharge will be diluted with the blow down from the cooling tower and the other discharges, before letting the same out to the ETP

	Environmental Impact Assessment Report of 18MW Co-Gen Power Plant by NBSSKL at Shahajinagar Post Redni, Dist Pune EME/CS/EIA- NBSSKL-IND/2012-13/108:R00dt.:28/11/2012	EIA Report (R-00)
---	--	--------------------------

9.6.5.3. Cooling Tower Blow Down

The usage of cooling water is high because the water cooled condenser system for the turbine and generator. In addition to the condenser, the auxiliaries of the turbine / generator, like the oil cooler and generator air cooler use cooling water. The cooling water is circulated through the condenser, the other coolers and through the cooling water. The cooling water is cooled by evaporative cooling and the cooling water consequently gets concentrated with the chemicals in the water.

The number of cycles of concentration is generally limited by the raw water quality and by the blow down water concentration. In addition, residual chlorine of about 0.2 ppm is maintained at the outlet of the cooling tower. This sodium hypochlorite dosing is done mainly to prevent biological growth in the cooling tower system. This will not result in any chemical pollution and also meets the national standards for the liquid effluent.

The level of pollutants from cooling tower will be minimized by reduced COC to 5 cycle. The cooling tower blow down water would be used for dust suppression. The low level of pollutants will be achieved by operating at sufficient blow down levels to prevent the build up of pollutants.

9.6.5.4. Boiler Blow Down

The pH and temperature of water are main factors for boiler blow down, as quantity of suspended solids is negligible. The pH will be in the range of 9.8 to 10.3 and the temperature of 100⁰C. The blow down is small and hence, it will be collected in a trench and connected to the effluent ponds. However, the main usage for blow-down water will be for ash quenching.

9.6.5.5. DM Plant Blow Down

The effluent from the cation resin units in the water treatment plant (DM plant) are acidic in nature and from the anion resin units are alkaline in nature. The combined wastewater from the DM plant would be neutralized in a neutralizing pit, if required lime dosing for final pH adjustment will be followed. The neutralized effluent is expected to have suspended solids.

This shall be pumped and mixed with other effluents & the entire treated waste water will be recycled and reused.

The expected quality of the treated effluent will meet the Inland surface and land disposal water quality standards and is presented in **Table 9.3**.

Table 9.3: Projected Treated Effluent Characteristics

Sl. No	Parameter	Value
1	pH	5.5 to 9.0
2	Oil & Grease (mg/l)	<10
3	TSS (mg/l)	<100
4	COD (mg/l)	<250
5	BOD (mg/l)	<30
6	Temperature, 0C	Not exceeding 5°C above the receiving water temperature
7	Total residual chlorine(mg/l)	<1.0
8	Fluoride, (mg/l)	<2.0
9	TDS, mg/l	<2100

9.6.5.6. Sewage

Sewage from various buildings in the factory area will be conveyed through separate drains to the septic tank. The effluent from the septic tank will be disposed in soil, by providing disposing trenches. There will be no ground pollution because of leaching. Sludge will be removed frequently used as manure for tress growth. Waste water treatment will be based on discharges of the various waste water to ponds for clarification and filtration. Oily water, if any, will be treated separately to remove oil / grease, before discharge into the effluent pond. The oily water collection in the plant is basically due to floor cleaning, leaky oil filters, etc. Provision for oil/grease separators will be made to skim oil / grease, if present in the waste water.

Final waste stream pH will be controlled to meet the norms of competent authority, by combining various streams to provide a neutral pH product. Where needed, acid or alkali addition will be used to achieve the final pH. Treated water will be used for gardening, ash quenching and for green fields.

	Environmental Impact Assessment Report of 18MW Co-Gen Power Plant by NBSSKL at Shahajinagar Post Redni, Dist Pune EME/CS/EIA- NBSSKL-IND/2012-13/108:R00dt.:28/11/2012	EIA Report (R-00)
---	---	--------------------------

Zero effluent discharge will be practiced by using recycled the waste water for dust suppression, plantation etc.

9.6.5.7. Monitoring of Wastewater Treatment

All the treated effluents will be monitored regularly for flow rate and its characteristics in order to assess the performance of the ETPs. Appropriate measures will be taken if the treated effluent quality does not conform to the permissible limits.

9.7 STORM WATER MANAGEMENT

Based on the rainfall intensity of the proposed area, storm water drainage system will be designed at the construction stage of the project. Storm water drainage system will consist of well-designed network of open surface drains with rainwater harvesting pits. A separate drainage system will be provided in which plant effluent will not be mixed.

* 9.8 RAIN WATER HARVESTING SCHEME

RWH structures will be provided to harvest the rain water from roof TOP and plant area. The collected rain water will be utilized for plant uses to optimize the raw water requirement. The surface water run-off from the main plant area would be led to a sump for settling and the over flow would be collected in the common water basin for further uses in the plant to optimize the raw water requirement of the plant. The excess rain water may be discharged to the nearest surface water body through dedicated storm water drain for recharging the ground water. Tentative Rainwater Harvesting System (RWHS) designs and construction details are given in the **Table 9.4** for ground water recharge system

- Rain Water Harvesting Structure (RWHS) for Ground water Recharge:
- Size: 1.5m x 1.5m x 2.0m

XEROX

Table 9.4: Construction Details of Rain Water Harvesting System For Ground Water Discharge

S.No	Volume, Cu.m	Description
1	4.5	Excavation in Hard Gravelly and all available soils
2	2.25	65 mm metal
3	1.25	20 mm metal
4	0.675	Coarse sand
5	0.24	CRS masonry in 1:6 prop.
6	4.5	Carting of excavated earth outside RWHS

**RAIN WATER HARVESTING STRUCTURE
TYPE - II
SIZE 1.0 x 1.0 x 1.5 mts**

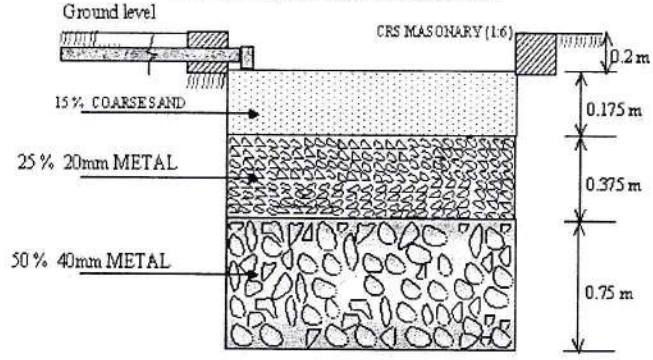

SECTION AT x x

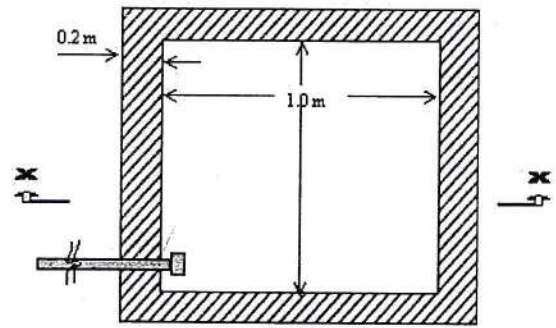

PLAN

Figure 9.2 : Tentative Rain Water Harvesting Structure

	Environmental Impact Assessment Report of 18MW Co-Gen Power Plant by NBSSKL at Shahajinagar Post Redni, Dist Pune EME/CS/EIA- NBSSKL-IND/2012-13/108:R00dt.:28/11/2012	EIA Report (R-00)
---	--	--------------------------

9.9 HOUSEKEEPING

Salient features of the practices to be adopted are as follows:

- Mechanized cleaning of roads and floor area inside the plant premises will be carried out;
- Training on regular basis to all workers and staff about the importance of cleanliness;
- Careful garbage transportation to dumping site and disinfection of transport vehicles body;
- Decorative plantation to improve aesthetics of the plant
- Construction of suitably designed drains all along the roads and boundary of the plant premises.

9.10 OCCUPATIONAL HEALTH & SAFETY

During construction stage, dust is the main health hazard. Other health hazards are due to gas cutting, welding, noise and high temperature and micro ambient conditions especially near the boiler and platforms which may lead to adverse effects (Heat cramps, heat exhaustion and heat stress reaction) leading to local and systemic disorders.

The precautionary measures which will be followed to reduce the risk due to dust to the workers engaged in and around the material handling areas are:

- Adequate arrangements for preventing generation of dust by providing the chutes at transfer points to reduce the falling height of material, preventing spillage of material by maintaining the handling equipment, isolating the high dust generating areas by enclosing them in appropriate housing and appropriately de-dusting through high efficiency bag filters;
- Almost all material handling systems will be automated thereby reducing the manpower. The workers engaged in material handling area will be provided with personal protective equipment like dust masks, respirators, helmets, face shields etc;
- All workers engaged in material handling system will be regularly examined through PFT (Pulmonary Function Test) tests for lung diseases;
- Thermal insulation will be provided wherever necessary to minimize heat radiation from the equipment, piping, etc. to ensure protection of workers. Insulation will be done by adequate cleats, wire nets, jackets etc. to avoid loosening. Insulation thickness will

	Environmental Impact Assessment Report of 18MW Co-Gen Power Plant by NBSSKL at Shahajinagar Post Redni, Dist Pune EME/CS/EIA- NBSSKL-IND/2012-13/108:R00dt.:28/11/2012	EIA Report (R-00)
---	--	--------------------------

be such that the covering jacket surface temperature does not exceed the surrounding ambient temperature by more than 15oC.

9.11 ECOLOGICAL MONITORING

Flora and fauna inventories within the factory area will be monitored on a twice yearly basis, as well as before and during the construction and early operating activities. This may involve the use of specific indicators, such as the occurrence of nests or nesting bird species of importance. It is intended that the implementation of the monitoring program will be conducted by NBSSKL. During the construction phase, the Project Manager will be responsible for overseeing land clearing activities and be involved in the scheduling of these activities in order to prevent them from being undertaken during periods of heavy rainfall whenever possible. However, in the event the scheduling of the activities must be undertaken during periods of heavy rainfall measures will be employed to reduce the risks of erosion.

9.12 GREEN BELT DEVELOPMENT PLAN

The main objective of the green belt is to provide a buffer zone between the sources of pollution and the surrounding areas. The green belt helps to capture the fugitive emissions and attenuate the noise apart from improving the aesthetics quality of the region. An area of about 27 acres for greenbelt already developed by NBSSKL in existing plant premises. Further NBSSKL has planned to strengthen the existing greenbelt by sampling new trees in proposed activity. Details of existing green belt attached as an **Annexure7**.

The plant species recommended for the greenbelt development are presented in **Table 9.5**. Approximately 2500 trees per ha will be planted in consultation with the local Forest Department.

The general guidelines for development of greenbelt will be as follows:

- Trees growing up to 5 m or more will be planted along the plant premises and along the road sides
- Planting of trees will be undertaken in rows.
- Open areas inside the plant boundary will be covered with grass.

	Environmental Impact Assessment Report of 18MW Co-Gen Power Plant by NBSSKL at Shahajinagar Post Redni, Dist Pune EME/CS/EIA- NBSSKL-IND/2012-13/108:R00dt.:28/11/2012	EIA Report (R-00)
---	---	--------------------------

- The spacing between the trees will be maintained slightly less than the normal spaces, so that the trees will grow vertically and slightly increase the effective height of the green belt.
- Planting of trees in each row will be in staggered orientation.
- In the front row, shrubs consisting of Callistemon, Prosopis etc. will be grown.
- Since the trunks of the tall trees are generally devoid of foliage, it will be useful to have shrubs in front of the trees so as to give coverage to this portion.
- Shrubs and trees will be planted in encircling rows around the project site.
- The small trees (<10 m height) will be planted in the first two rows (towards plant side) of the green belt. The tall trees (>10 m height) will be planted in the outer three rows (away from plant side).
- For adsorption of dust and gaseous pollutants the following types of plants will be considered,
 - Fast growing
 - Thick canopy cover
 - Longer duration of foliage.
 - Adequate height and spread of crown
 - Big leaves (long and broad laminar surfaces) supported by firm petioles.
 - Large number of stomata apertures. (Large leaf area index)
 - Perennial and evergreen
 - Abundance of surfaces on bark and foliage through roughness of bark, epidermal outgrowth on petioles, abundance of auxiliary hairs, hairs or scales on laminar surfaces and protected stomata (by wax, arches, rings, hairs, etc.)
- The choice of plants will include shrubs that grow 1 to 2 m high and trees of 3 to 5m heights. It will be ensured that the foliage area density in vertical is almost uniform by intermixing the trees and shrubs. Since safety during transport is a major consideration, shrubs in traffic islands and along road dividers will be short enough to be below the eye-level of motorists.
- The species identified for greenbelt development will be planted using pitting technique. The pit size will be either 45 cm X 45 cm X 45 cm or 60 cm X 60 cm X 60 cm .Bigger pit size will be preferred. Soil used for filling the pit will be mixed well with decomposed farm yard manure or sewage sludge at the rate of 2.5 kg (on dry weight



basis) and 3.6 kg (on dry weight basis) for 45 cm X 45 cm X 45 cm and 60 cm X 60 cm X 60 cm pit respectively. The filling of soil will be completed at least 5-10 days before actual plantation.

Table 9.5: Plant Species Suggested For Green Belt Development

SrNo	Botanical name	Habit	Growth rate	Evergreen /Deciduous	Sensitive /Tolerant
1	<i>Abutilon indicum</i> Linn	Shrub	Quick growing	Deciduous	Tolerant
2	<i>Acacia auriculiformis</i> A. cunn.	Tree	Quick growing	Evergreen	Tolerant
3	<i>Acacia catechu</i> , Willd	Shrub	Quick growing	Evergreen	Tolerant
4	<i>Acacia nilotica</i> (Linn) Willd	Tree	Quick growing	Evergreen	Tolerant
5	<i>Acacia pennata</i> Willd	Shrub	Quick growing	Evergreen	Tolerant
6	<i>Acacia Polyacantha</i> Willd	Tree	Quick growing	Semi – deciduous	Tolerant
7	<i>Acacia senegal</i> Willd	Tree	Quick growing	Deciduous	Tolerant
8	<i>Acacia sinuata</i> (Lour) Merrill	Tree	Quick growing	-----	Tolerant
9	<i>Acacia tortilis</i> Hayne	Tree	Quick growing	----	Tolerant
10	<i>Achrassapota</i> Linn	Tree	Slow growing during early stages	Evergreen	Tolerant
11	<i>Actinodaphneangustifolia</i> Nees	Tree	Slow	Evergreen	Tolerant
12	<i>Adenantherapavonina</i> Linn	Tree	Quick growing	Deciduous	Tolerant
13	<i>Adina cordifolia</i> Raxb.	Tree	Slow growing	Deciduous	Tolerant
14	<i>Aeglemarmelos</i> (Linn) Correa	Tree	Slow growing	Evergreen	Tolerant
15	<i>Ailanthus excels</i> Raxb.	Tree	Quick growing	Deciduous	Tolerant
16	<i>Albiziaamara</i> Boiv	Tree	Quick growing	Deciduous	Tolerant
17	<i>Albizialebeck</i> Benth	Tree	Quick growing	Deciduous	Tolerant
18	<i>Albiziamoluccana</i> Mig.	Tree	Quick growing	Evergreen	Tolerant
19	<i>Albiziaodorrattissima</i> Benth.	Tree	Quick growing	Evergreen	Tolerant
20	<i>Balanitesroxburghii</i> Planch	Tree	Quick growing	Evergreen	Tolerant
21	<i>Bambusaarundinacia</i> (Retz) Roxb	Shrub	Quick growing	Deciduous	Tolerant

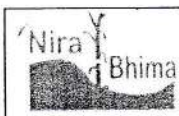

22	<i>Bambusa vulgaris Schrad.</i>	Shrub / tall perennial grasses.	Quick growing	Deciduous	Tolerant
23	<i>Barringtonia acutangla (L) Gaertn.</i>	Tree	Quick growing	Evergreen	Tolerant
24	<i>Bauhinia acuminata Linn.</i>	Shrub	Quick growing	Deciduous	Tolerant
25	<i>Bauhinia purpurea Linn</i>	Tree	Quick growing	Deciduous	Tolerant
26	<i>Bauhinia recemosa Lamk</i>	Small tree	Quick growing	Deciduous	Tolerant
27	<i>Bauhinia semla Wanderlin</i>	Tree	Quick growing	Deciduous	Tolerant
28	<i>Bauhinia varigata Linn</i>	Tree	Quick growing	Deciduous	Tolerant
29	<i>Bischofia javanica Blume</i>	Tree	Quick growing	Deciduous	Tolerant
30	<i>Caesalpinia pulcherrima (L) Swartz</i>	-----	Quick growing	Evergreen	Tolerant
31	<i>Callistemon citrinus (Curtis) stapf.</i>	Small tree	Slow growing	Evergreen	Tolerant
32	<i>Calophyllum inophyllum Linn</i>	Tree	Slow growing	Evergreen	Tolerant
33	<i>Calotropis gigantea R.Br. (Linn)</i>	Shrub	Quick growing	Evergreen	Tolerant
34	<i>Carrisa spinarum Linn</i>	Shrub	Quick growing	Evergreen	Tolerant
35	<i>Cassia fistula Linn</i>	Tree	Quick growing	Deciduous	Tolerant
36	<i>Cassia renigera Wall Ex. Benth</i>	Tree	Quick growing	Deciduous	Tolerant
37	<i>Cassia siamea Lamk</i>	Tree	Fast growing	Evergreen	Tolerant
38	<i>Dalbergia latifolia Roxb.</i>	Tree	Quick growing	Semi – deciduous	Tolerant
39	<i>Dalbergia sisoo Roxb.</i>	Tree	Moderate during 1 st year and rapid afterwards	Evergreen	Tolerant
40	<i>Emblica officinalis Gaertn</i>	Tree	Quick growing	Deciduous	Tolerant
41	<i>Embryopteris peregrina Gaertn</i>	Tree	Quick growing	Deciduous	Tolerant
42	<i>Erythrina variegata Linn</i>	Tree	Quick growing	Deciduous	Tolerant
43	<i>Eucalyptus hybrid</i>	Tree	Quick growing	Evergreen	Tolerant
44	<i>Ficus benghalensis Linn</i>	Tree	Quick growing	Evergreen	Tolerant
45	<i>Ficus benjamina Linn</i>	Tree	Quick growing	Evergreen	Tolerant
46	<i>Ficus salsatica Roxb.</i>	Tree (Epiphytic)	Quick growing	Evergreen	Tolerant

	Environmental Impact Assessment Report of 18MW Co-Gen Power Plant by NBSSKL at Shahajinagar Post Redni, Dist Pune EME/CS/EIA- NBSSKL-IND/2012-13/108:R00dt.:28/11/2012	EIA Report (R-00)
---	---	--------------------------

47	<i>FicusgibbosaBlume</i>	Tree	Quick growing	Evergreen	Tolerant
48	<i>GarciniatalbottiRaizada</i>	Tree	Slow growing	Evergreen	Tolerant
49	<i>Gardenia jasminoidesEills</i>	Tree	Quick growing	Evergreen	Tolerant
50	<i>Hamelia patens Jacq</i>	Shrub	Quick growing	Evergreen	Tolerant
51	<i>Heterophragamaroxburghii DC</i>	Tree	Quick growing	Evergreen	Tolerant
52	<i>Hisbicusrosa – sinensis Linn</i>	Shrub	Quick growing	Evergreen	Tolerant
53	<i>IxoraarboreaRoxb</i>	Tree	Quick growing	Evergreen	Tolerant
54	<i>Ixorachinensis</i>	Shrub	Quick growing	Evergreen	Tolerant
55	<i>Juniperuscommunis</i>	Shrub	Quick growing	Evergreen	Sensitive
56	<i>KigeliaafricanaLamk</i>	Small Tree	Quick growing	Evergreen	Tolerant

9.13 MEASURES TO IMPROVE SOCIO-ECONOMIC CONDITIONS

The proposed project will generate employment opportunity for skilled and semi skilled persons during construction and operation phase. As per census data it was found that 29006 are non-workers in the study area. Proposed project will definitely helpful in creation of new jobs, small business development etc. It is envisaged to implement welfare measures including provision of basic facilities/amenities. NBSSKL will improve the socio-economic status of the local habitants and proposes to provide scholarships to poor children undertake nursery plantation and conduct health camps. Moreover, provision will be made to provide potable water, schools, and sanitation facilities etc. for the neighboring villages.

Further with the development of industrial and commercial activity in the area there is likelihood of detrainning of human values as observed elsewhere in the similar industrial developments. Effective education and enhanced social activities will help to maintain the human values in the region.

The presence of the industry will enhance job opportunities and commercial activities, which inturn will improve the economic conditions of the population. Service infrastructure like transportation, health care, education, communication facilities may improve considerably. The availability of power from the industry will help to reduce the power scarcity and frequent power failures in the region by stabilization of the power in the grid, which will improve power supply to irrigation pump sets and house hold requirements.

	Environmental Impact Assessment Report of 18MW Co-Gen Power Plant by NBSSKL at Shahajinagar Post Redni, Dist Pune EME/CS/EIA- NBSSKL-IND/2012-13/108:R00dt.:28/11/2012	EIA Report (R-00)
---	--	--------------------------

9.14 FIRE FIGHTING & PROTECTION SYSTEM

9.14.1. General

The fire fighting system will be designed in conformity with the recommendations of the Tariff Advisory Committee (TAC) of Insurance Association of India. While designing the fire protection systems for this power station its extreme ambient conditions need special attention. Codes and Standards of National Fire Protection Association (NFPA) will be followed, as applicable. The different types of fire protection / detection system envisaged for the entire project are given below.

- Hydrant System for entire area of power plant.
- High Velocity Water Spray System (HVWS) for Generator Transformer (GT), Unit Auxiliary transformer (UAT), Station Transformer (ST), and turbine lube oil canal pipe lines in main plant, Boiler burner front, diesel oil tank of DG set, main lube oil tank, clean and dirty lube oil tanks.
- Medium Velocity Water spray system – Cable gallery / Cable spreader room, bagasse conveyors, Transfer points and F.O. pumping station and F.O. tanks.
- Foam system for Fuel oil tanks.
- Portable and mobile fire extinguishers for entire plant.
- Fire tenders (minimum 2 nos.).
- Inert Gas System for Central Control Room, Control Equipment Room, Computer Room and UPS Room in the TG building.
- Fixed Foam System : This system is provided for LDO and HFO storage tanks. The water for the foam system will be tapped from the Hydrant system.
- Inert gas system :Inert gas system will automatically detect and suppress fire within a protected area. The system will be a total flooding fire suppression system with automatic detection and/or manual release capability. Complete system design will be in accordance with NFPA. The inert gas system will be generally provided above false and below false ceiling of Central Control room, UPS Room, Control equipment room and Computer room.

	Environmental Impact Assessment Report of 18MW Co-Gen Power Plant by NBSSKL at Shahajinagar Post Redni, Dist Pune EME/CS/EIA- NBSSKL-IND/2012-13/108:R00dt.:28/11/2012	EIA Report (R-00)
---	---	--------------------------

9.14.2. Fire Detection and Alarm System

Fire Detection and Alarm system will be provided for all Central Control room, Control Equipment Room, battery rooms, all switchgear rooms / MCC rooms, Cable spreader room and Computer rooms located in Power block area and in other auxiliary buildings.

A microprocessor-based Fire Detection and Alarm system shall be provided for the entire plant area consisting of Intelligent Analog Addressable type detectors. The system will consist of a central monitoring station and the main Fire Alarm Panel (FAP) located in unit control room and one fire alarm and control panel and repeater panel provided in the fire station office

An industrial siren will be installed in the turbine generator building. The siren shall have an audible range of 3 Km and produce a minimum sound level of 80 dB (A) above any other noise likely to persist for a period longer than 30 seconds. Additionally all exit routes and hallways in each occupied building shall be provided with sounders and flash light to facilitate safe evacuation in case of fire in the area.

All necessary instruction and warning plates will be displayed.

9.15 BUDGETARY PROVISION FOR ENVIRONMENTAL MANAGEMENT PLAN

- The Capital Cost of the proposed 18 MW Cogen Power Plant is 8781.70 (as proposed to be approved by the funding agency/financial institution).
- Cost of EMP is Rs 280. Lakhs .

A Total capital & recurring cost EMP are presented in **Table 9.6**

Table 9.6: Budgetary allocation for environmental protection measures

No.	Particulars	Amount in INR, Lakhs
One Time Installation Cost (Capital Cost)		
1	Air Pollution Control System	200.00
2	Noise Control System	20.00
3	Green Belt Development	25.00
4	Environment Monitoring and Management	25.00
5	Occupational Health & Safety	10.0
	Total	280.00
Recurring Cost		
1	Environmental Monitoring/APH Maintenance	12.00
2	General Maintenance of ETP	15.00
3	Greenbelt maintenance	2.50
	Noise Pollution Control	2.00
4	Occupational Health	2.50
5	Environmental Management	5.00
	Total	39.00

*A COPY OF CONSENT TO ESTABLISH
AND
CONSENT TO OERATE
FROM
MAHARASHTRA POLLUTION CONTROL BOARD*

MAHARASHTRA POLLUTION CONTROL BOARD

Tel: 24010437/24020781/24014701
 Fax: 24024068 /24023515
 Website: <http://mpcb.gov.in>
 E-mail: mpcb@vsnl.net



Kalpataru Point, 2nd - 4th Floor,
 Opp. Cine Planet Cinema,
 Near Sion Circle, Sion (E)
 Mumbai - 400 022

Red/LSI

Date: 14/08/2013

Consent No: Format 1.0/BO/ID(WPC)/EIC No. PN-16784-13/E/CAC-6801

To,
 M/s Nira Bhima SSK Ltd. (Sugar & Cogeneration)
 At-Shahajinagar, Post-Redni, Tal-Indapur
 Pune-413114

Subject: Consent to Establish under RED category.

Ref :- I. Minutes of Consent Appraisal Committee Meeting held on 29.07.2013.

Your application dated 21.01.2013.

For: Consent to Establish under Section 25 of the Water (Prevention & Control of Pollution) Act, 1974 & under Section 21 of the Air (Prevention & Control of Pollution) Act, 1981 and Authorization under Rule 5 of the Hazardous Wastes (M, H & T M) Rules 2008 is considered and the consent is hereby granted subject to the following terms and conditions and as detailed in the schedule I, II, III & IV annexed to this order:

- The consent is granted for a period up to: Commissioning of the unit or five years from the date 02.08.2012 whichever is earlier.
- The proposed capital investment for expansion of the industry is Rs. 166.06 Cr. (As per Certificate submitted by industry for Sugar unit + Co-Gen unit.)
- The Consent is valid for the manufacture of -

Sr.No.	Product Name	Maximum Quantity in MT/M.
1	White Crystal Sugar	8100 MT/M.
2	Molasses	2700 MT/M.
3	Bagasse	20000 MT/M.
4	Press mud	2700 MT/M.
5	Electricity Generation (Co- Gen)	18 MW.

(The cane crushing Capacity of Sugar Industry shall not exceed 3500 TCD)

Conditions under Water (P&CP), 1974 Act for discharge of effluent:

Sr. no.	Description	Permitted quantity of discharge (CMD)	Standards to be achieved	Disposal
1.	Trade effluent	Sugar + Co-gen. 435	As per Schedule -I	On land for irrigation
2.	Domestic effluent	32	As per Schedule -I	On land for irrigation

copy to
 CA/EE/CC
 14/8/13
 1.

[Handwritten Signature]

SRO Pune 14/8/13/20602004
 9288 9/1/13
[Handwritten Signature]



5. Conditions under Air (P& CP) Act, 1981 for air emissions:

Sr. no.	Description of stack / source	Number of Stack	Standards to be achieved
1.	Boiler	01	As per Schedule - II

6. Conditions under Hazardous Waste (M, H & T M) Rules, 2008 for treatment and disposal of hazardous waste:

Sr.No.	Type of Waste	Category	Quantity	UOM	Disposal
1	Used /Spent Oil	5.1	As and when generated	—	Reuse in own boiler as fuel

Non-Hazardous Solid Wastes:

Sr.No.	Type of Waste	Quantity	UOM	Treatment	Disposal
1	Fly Ash	445	MT/M	-	Sale to Bricks manufacturers

- This Board reserves the right to review, amend, suspend, revoke etc. this consent and the same shall be binding on the industry.
- This consent should not be construed as exemption from obtaining necessary NOC/permission from any other Government agencies.
- The industry shall not take any effective steps for implementation of the project before obtaining Environmental Clearance as per EIA Notification, 2006 and Amendments thereto.
- This consent is issued with overriding effect to the earlier consent No. BO/JD(WPC)/EIC-PN-13943-12/E/CC-CAC-548, dt. 02/08/2012.



For and on behalf of the
Maharashtra Pollution Control Board

(V.M. Motghare) *[Signature]*
Member Secretary

Received Consent fee of -

Sr.No.	Amount (₹)	DD No.	Date	Drawn On
1	282422	694836	29 th Feb 2012	Bank of India
2	49808	259572	24 th Dec 2012	Bank of India

Copy to:

- Regional Officer MPCB Pune, and Sub -Regional Officer - MPCB Pune-I, They are directed to ensure the compliance of the consent conditions.
- Chief Accounts Officer, MPCB, Mumbai.
- CC/CAC desk- for record & website updation purposes.

Schedule-I

D) Terms & Conditions for compliance of Water Pollution Control

- 1) A) As per your application, you have proposed to install the Effluent Treatment Plant (ETP) with the design capacity of 700 CMD.
- B) The Applicant shall operate the effluent treatment plant (ETP) to treat the trade effluent so as to achieve the following standards prescribed by the Board or under EP Act, 1986 and Rules made there under from time to time, whichever is stringent.

Sr. No.	Parameters	Standards prescribed by Board
		Limiting Concentration in mg/l, except for pH
01	pH	5.5-9.0
02	Oil & Grease	10
03	BOD (3 days 27°C)	30
04	Sulphate	1000
05	Suspended Solids	100
06	COD	250
07	Chloride	600
08	Total Dissolved Solids	2100

C) The treated effluent shall be disposed on land for irrigation on 113 Acres of own Land.

D) CREP conditions for Sugar Factory

- i. Operation of ETP shall be started at least one month before starting of cane crushing to achieve desired MLSS. So as to meet prescribed standards from day one the operation of mill.
- ii. Waste water generation shall be reduced to 100 litres per tone of cane crushed.
- iii. Industry shall achieve zero discharge into in land surface water bodies.
- iv. 15 days storage capacity tank shall be provided for treated effluent to take care of no demand for irrigation.

E) Industry to make necessary arrangement to cover the effluent collection system and to avoid the ingress of Bagasse other material

2) A) As per your consent application, you have proposed to install sewage treatment system with the design capacity of --- CMD.

B) The Applicant shall operate the sewage treatment system to treat the sewage so as to achieve the following standards.

- | | | | | |
|-----|------------------|---------------|-----|-------|
| (1) | Suspended Solids | Not to exceed | 100 | mg/l. |
| (2) | BOD 3 days 27°C | Not to exceed | 100 | mg/l. |

C) The treated sewage shall be disposed on land for gardening/irrigation.



- 3) The industry shall have bilateral agreement with the farmers on whose land the treated effluent is used for irrigation purposes and a copy of the agreements with validity shall be submitted to the Regional/Sub- Regional Office of the Board.
- 4) The industry shall create Environmental Cell by appointing an Environmental Engineer, Chemist and Agriculture expert for looking after day to day activities related to Environment and irrigation field where treated effluent is used for irrigation.
- 5) **CONDITIONS FOR MOLASSES STORAGE:**
 - (i) The molasses shall be properly collected and stored in steel tanks which shall be leak proof. At no stage of handling of molasses, there shall be leakage or spillage.
 - (ii) The capacity of tanks for storage of molasses shall be such that it will take care of bumper production of sugar, non-lifting of molasses etc.
 - (iii) All the area on which molasses are stored and handled should be provided with drain for diverting the spills to the treatment plant/ molasses tank. Suitable arrangements for accidental discharges of molasses from the tanks shall be provided to contain the same within factory premises.
 - (iv) Destruction of molasses and its disposal shall not be done without specific permission in writing from the authorized officer of the Board. Intimation of intention to destroy or dispose of the molasses shall be given to the Board atleast 15 (fifteen) days in advance by registered post under intimation to the Sub-Regional officer and Regional officer of the Board under whose jurisdiction the factory is situated.
 - (v) The storage tanks shall be kept in good conditions all the year round with adequate maintenance. The tanks size and capacity per cm, height, total capacity in tonnes shall be displayed prominently near /on the tank.
 - (vi) The above conditions shall be in addition to and not in derogation of the provisions contained in the "Bombay Molasses Rules, 1955" and "Maharashtra Molasses Storage and Supply Regulation, 1965".
- 6) The Board reserves its rights to review plans, specifications or other data relating to plant-setup for the treatment of waterworks for the purification thereof & the system for the disposal of sewage or trade effluent or in connection with the grant of any consent conditions. The Applicant shall obtain prior consent of the Board to take steps to establish the unit or establish any treatment and disposal system or an extension or addition thereto.
- 7) The industry shall ensure replacement of pollution control system or its parts after expiry of its expected life as defined by manufacturer so as to ensure the compliance of standards and safety of the operation thereof.
- 8) The Applicant shall provide Specific Water Pollution control system as per the conditions of EP Act, 1986 and rule made there under from time to time/ Environmental Clearance / CREP guidelines if applicable.



II) Conditions under Water (Prevention & Control of Pollution) CESS Act, 1977 as amended

The Applicant shall comply with the provisions of the Water (Prevention & Control of Pollution) Cess Act, 1977 and as amended, by installing water meters, filing water cess returns in Form-I and other provisions as contained in the said act.

Sr. No.	Purpose for water consumed	Water consumption quantity (CMD) (Sugar)	Water consumption quantity (CMD) (Co-Gen)
1.	Industrial Cooling, boiler feed etc.,	282	10
2.	Domestic purpose	40	
3.	Processing whereby water gets polluted & pollutants are easily biodegradable	488	30
4.	Processing whereby water gets polluted & pollutants are not easily biodegradable and are toxic	—	—



Schedule-II

Terms & conditions for compliance of Air Pollution Control

1. As per your application, you have proposed the Air pollution control (APC) system and also proposed to erect following stack (s) to observe the following fuel pattern-

Sr. No.	Stack Attached to	Height in meter	Type of Fuel	Quantity	DOM	S %	SO ₂ Kg/Day
1	Boiler (66 TPH)	75	Bagasse	566	MT/day	—	2264
			Biogas	500	M3/Hr	---	---

2. The Applicant shall provide ESP/ Bag filter/ Wet scrubber to the Bagasse fired boiler and Dust Collector to Sugar bagging section as an Air Pollution control equipments OR as per the conditions of EP Act, 1986 and rule made there under from time to time / Environmental Clearance / CREP guidelines.
3. The applicant shall operate and maintain above mentioned air pollution control system, so as to achieve the level of pollutants to the following standards:
- | | | |
|--------------------|---------------|-------------------------|
| Particulate matter | Not to exceed | 150 mg/Num ³ |
|--------------------|---------------|-------------------------|
4. The Applicant shall obtain necessary prior permission for providing additional control equipment with necessary specifications and operation thereof or alteration or replacement/alteration well before its life come to an end or erection of new pollution control equipment.
5. The Board reserves its rights to vary all or any of the condition in the consent, if due to any technological improvement or otherwise such variation (including the change of any control equipment, other in whole or in part is necessary).



Schedule-III
Details of Bank Guarantees

Sr. No.	Consent	Amt of BG Imposed	Submission Period	Purpose of BG	Compliance Period	Validity Date
1	C to E for expansion	Rs. 5.0 Lakhs	15 Days	Towards condition of not to take any effective steps for implementation of the project till obtaining Environmental Clearance.	---	31/12/2017



[Signature]

Schedule-IV
General Conditions

- 1) The applicant shall provide facility for collection of environmental samples and samples of trade and sewage effluents, air emissions and hazardous waste to the Board staff at the terminal or designated points and shall pay to the Board for the services rendered in this behalf.
- 2) Industry should monitor effluent quality, stack emissions and ambient air quality monthly/quarterly.
- 3) The applicant shall provide ports in the chimney/(s) and facilities such as ladder, platform etc. for monitoring the air emissions and the same shall be open for inspection to/and for use of the Board's Staff. The chimney(s) vents attached to various sources of emission shall be designated by numbers such as S-1, S-2, etc. and these shall be painted/ displayed to facilitate identification.
- 4) Whenever due to any accident or other unforeseen act or even, such emissions occur or is apprehended to occur in excess of standards laid down, such information shall be forthwith Reported to Board, concerned Police Station, office of Directorate of Health Services, Department of Explosives, Inspectorate of Factories and Local Body. In case of failure of pollution control equipments, the production process connected to it shall be stopped.
- 5) The applicant shall provide an alternate electric power source sufficient to operate all pollution control facilities installed to maintain compliance with the terms and conditions of the consent. In the absence, the applicant shall stop, reduce or otherwise, control production to abide by terms and conditions of this consent.
- 6) The firm shall submit to this office, the 30th day of September every year, the Environmental Statement Report for the financial year ending 31st March in the prescribed Form-V as per the provisions of rule 14 of the Environment (Protection) (Second Amendment) Rules, 1992.
- 7) The industry shall recycle/reprocess/reuse/recover Hazardous Waste as per the provision contain in the IIW (MH&TM) Rules 2008, which can be recycled /processed /reused /recovered and only waste which has to be incinerated shall go to incineration and waste which can be used for land filling and cannot be recycled/reprocessed etc should go for that purpose, in order to reduce load on incineration and landfill site/environment.
- 8) The industry should comply with the Hazardous Waste (M, H & TM) Rules, 2008 and submit the Annual Returns as per Rule 5(6) & 22(2) of Hazardous Waste (M, H & TM) Rules, 2008 for the preceding year April to March in Form-IV by 30th June of every year.
- 9) An inspection book shall be opened and made available to the Board's officers during their visit to the applicant.
- 10) The applicant shall obtain Consent to Operate from Maharashtra Pollution Control Board before actual commencement of the Unit/ Activity.
- 11) Industry shall strictly comply with the Water (P&CP) Act, 1974, Air (P&CP) Act, 1981 and Environmental Protection Act, 1986 and industry specific standard under EP Rules 1986 which are available on MPCB website (www.mpcb.gov.in).
- 12) The industry shall constitute an Environmental cell with qualified staff/personnel/agency to see the day to day compliance of consent condition towards Environment Protection.
- 13) Separate drainage system shall be provided for collection of trade and sewage effluents. Terminal manholes shall be provided at the end of the collection system with arrangement for measuring the flow. No effluent shall be admitted in the pipes/sewers downstream of the terminal manholes. No effluent shall find its way other than in designed and provided collection system.
- 14) Neither storm water nor discharge from other premises shall be allowed to mix with the effluents from the factory.



- 15) The applicant shall install a separate meter showing the consumption of energy for operation of domestic and industrial effluent treatment plants and air pollution control system. A register showing consumption of chemicals used for treatment shall be maintained.
- 16) The industry should not cause any nuisance in surrounding area.
- 17) The industry shall take adequate measures for control of noise levels from its own sources within the premises so as to maintain ambient air quality standard in respect of noise to less than 75 dB (A) during day time and 70 dB (A) during night time. Day time is reckoned in between 6 a.m. and 10 p.m. and night time is reckoned between 10 p.m. and 6 a.m.
- 18) The applicant shall maintain good housekeeping.
- 19) The applicant shall bring minimum 33% of the available open land under green coverage/ plantation. The applicant shall submit a yearly statement by 30th September every year on available open plot area, number of trees surviving as on 31st March of the year and number of trees planted by September end.
- 20) The non-hazardous solid waste arising in the factory premises, sweepings, etc. be disposed of scientifically so as not to cause any nuisance / pollution. The applicant shall take necessary permissions from civic authorities for disposal of solid waste.
- 21) The applicant shall not change or alter the quantity, quality, the rate of discharge, temperature or the mode of the effluent/emissions or hazardous wastes or control equipments provided for without previous written permission of the Board. The industry will not carry out any activity, for which this consent has not been granted/without prior consent of the Board.
- 22) The industry shall ensure that fugitive emissions from the activity are controlled so as to maintain clean and safe environment in and around the factory premises.
- 23) The industry shall submit quarterly statement in respect of industries obligation towards consent and pollution control compliance's duly supported with documentary evidences (format can downloaded from MPCB official site).
- 24) The industry shall submit official e-mail address and any change will be duly informed to the MPCB.
- 25) The industry shall achieve the National Ambient Air Quality standards prescribed vide Government of India, Notification dt 16.11.2009 as amended.
- 26) Transportation of coal & fly ash shall be by closed system, Conveyor system wherever possible.

-----0000-----

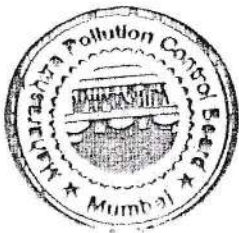

MAHARASHTRA POLLUTION CONTROL BOARD

Tel: 24010437/24020781/24014701

Fax: 24024068 /24023515

Website: <http://mpcb.gov.in>

E-mail: mpcb@vsnl.net



Kalpataru Point, 2nd - 4th Floor,
Opp. Cine Planet Cinema,
Near Sion Circle, Sion (E)
Mumbai - 400 022

Red/LSI

Consent No: ~~Format 1.0/BO/CAC-CELL/EIC No.PN-25773-15 /R/CAC-~~ 4176

Date: 23/03/2016.

To,
M/s. Nira Bhima SSK Ltd., (Sugar Co-gen),
At Shahajinagar, Post Redni, Tal. Indapur,
Dist. Pune. - 413 117

Subject : Renewal of Consent to Operate of 3500 TCD Sugar & 18 MW Co-generation unit under RED category.

- Ref : 1. Consent to Establish for expansion granted by the Board vide no. BO/JD(WPC) /EIC No. PN-16784-13/E/CAC-6801 dtd. 14.08.2013.
2. Consent to Operate granted by the Board to the existing unit vide No. BO/CAC-CELL/EIC-PN--13/CAC-9041 dtd. 28.10.2013.
3. Minutes of CAC meeting held on 02.02.2016.

Your application: CR1511000055.

Dated: 11.08.2015.

For: Renewal of Consent to Operate of 3500 TCD Sugar & 18 MW Co-generation unit under RED category, under Section 26 of the Water (Prevention & Control of Pollution) Act, 1974 & under Section 21 of the Air (Prevention & Control of Pollution) Act, 1981 and Authorization under Rule 5 of the Hazardous Wastes (M, H & T M) Rules 2008 is considered and the consent is hereby granted subject to the following terms and conditions and as detailed in the schedule I, II, III & IV annexed to this order:

- The consent is granted for a period up to 31.07.2016.
- The actual total investment of the industry is Rs. 215.82 Cr. (As per C. A. Certificate submitted by industry)
- The Consent is valid for the manufacture of -

Sr. No.	Product / By-Product Name	Maximum Quantity in MT/M
1	Sugar	12600
2	Molasses	4400
3	Pressmud	4300
4	Bagasse	45000
5	Electric Power (Cogeneration)	18 MW

(The cane crushing Capacity of Sugar Industry shall not exceed 3500 TCD)

- Conditions under Water (P&CP), 1974 Act for discharge of effluent:

Sr. no.	Description	Permitted quantity of discharge (CMD)	Standards to be achieved	Disposal
1.	Trade effluent	685 (Sugar 278 + Co-gen 407)	As per Schedule -I	407 CMD 100% recycle & 278 CMD on land for irrigation
2.	Domestic effluent	15	As per Schedule -I	On land for irrigation

3 APR 2016



5. Conditions under Air (P& CP) Act, 1981 for air emissions:

Sr. no.	Description of stack / source	Number of Stack	Standards to be achieved
1.	Boiler (66 TPH)	1	As per Schedule - II
2.	Boiler (40 TPH)	1	As per Schedule - II

6. Conditions under Hazardous Waste (M, H & T M) Rules, 2008 for treatment and disposal of hazardous waste:

Sr. No.	Type of Waste	Category	Quantity	UOM	Disposal
1	Used /Spent Oil	5.1	200	Kg/M	Reuse in own boiler as fuel

9. Non-Hazardous Solid Wastes:

Sr. No.	Type of Waste	Quantity	UOM	Treatment	Disposal
1.	Fly/Boiler Ash	451	MT/M	-	Sale to Bricks manufacturers and used for compost production.

10. This Board reserves the right to review, amend, suspend, revoke etc. this consent and the same shall be binding on the industry.
11. This consent should not be construed as exemption from obtaining necessary NOC/permission from any other Government agencies.
12. Industry shall operate online monitoring system which is installed as per the Directions of CPCB and shall connect/ upload the online monitoring data at MPCB and CPCB server.

For and on behalf of the
Maharashtra Pollution Control Board



(Dr. P. Anbalagan, IAS)
Member Secretary

Received Consent fee of -

Sr. No.	Amount (Rs.)	DD. No.	Date	Drawn On
1	Rs. 4,31,744/-	669014	669014	Bank of India

Copy to:

- Regional Officer - MPCB Pune & Sub -Regional Officer - Pune-I, MPCB, They are directed to ensure the compliance of the consent conditions.
- Chief Accounts Officer, MPCB, Mumbai.
- CC/CAC desk- for record & website updation purposes.

Schedule-I

D) Terms & Conditions for compliance of Water Pollution Control

- 1) A) As per your application, you have provided Effluent Treatment Plant design Capacity of 700 CMD.
- B) The Applicant shall operate the effluent treatment plant (ETP) to treat the trade effluent so as to achieve the following standards prescribed by the Board or under EP Act, 1986 and Rules made there under from time to time, whichever is stringent.

Sr. No.	Parameters	Standards prescribed by Board
Limiting Concentration in mg/l, except for pH		
01	pH	5.5-9.0
02	Oil & Grease	10
03	BOD (3 days 27°C)	100
04	Sulphate	1000
05	Suspended Solids	100
06	COD	250
07	Chloride	600
08	Total Dissolved Solids	2100

- C) The treated effluent 278 CMD generated from Sugar unit shall be disposed on land for irrigation on 50 acres of own land /as per the bilateral agreement with farmers. **In no case treated/untreated effluent shall find its way outside the factory premises directly or indirectly.**
- D) **Trade effluent of 407 CMD generated from Co-gen shall be 100% recycle in process.**
- E) CREP conditions for Sugar Factory
- Operation of ETP shall be started at least one month before starting of cane crushing to achieve desired MLSS. So as to meet prescribed standards from day one the operation of mill.
 - Waste water generation shall be maintained as 100 liters per ton of cane crushed.
 - Industry shall achieve zero discharge into in land surface water bodies.
 - 15 days storage capacity tank shall be provided for treated effluent to take care of no demand for irrigation.
- F) Industry shall maintain properly the arrangement provided for covering the effluent collection system and to avoid the ingress of Bagasse other material.
- G) **The unit shall operate ETP even after completion of the crushing season so that any effluent generated during washing & maintenance is discharged after proper treatment.**
- H) **The unit shall optimize water use in industrial process & maintain records of water consumption & waste water generation.**

- 2) A) As per your consent application, for the 18 CMD sewage generation you have provided septic tank & soak pit for the treatment of sewage.
- B) The Applicant shall operate the sewage treatment system to treat the sewage so as to achieve the following standards
- | | | | |
|-----|-------------------------|----------------------|------------------|
| (1) | Suspended Solids | Not to exceed | 100 mg/l. |
| (2) | BOD 3 days 27°C | Not to exceed | 100 mg/l. |
- C) The treated sewage shall be disposed on land for gardening/irrigation.



- 3) The industry shall have bilateral agreement with the farmers on whose land the treated effluent is used for irrigation purposes and a copy of the agreements with validity shall be submitted to the Regional/Sub-Regional Office of the Board.
- 4) The industry shall create Environmental Cell by appointing an Environmental Engineer, Chemist and Agriculture expert for looking after day to day activities related to Environment and irrigation field where treated effluent is used for irrigation.
- 5) **CONDITIONS FOR MOLASSES STORAGE:**
 - (i) The molasses shall be properly collected and stored in steel tanks which shall be leak proof. At no stage of handling of molasses, there shall be leakage or spillage.
 - (ii) The capacity of tanks for storage of molasses shall be such that it will take care of bumper production of sugar, non-lifting of molasses etc.
 - (iii) All the area on which molasses are stored and handled should be provided with drain for diverting the spills to the treatment plant/ molasses tank. Suitable arrangements for accidental discharges of molasses from the tanks shall be provided to contain the same within factory premises.
 - (iv) Destruction of molasses and its disposal shall not be done without specific permission in writing from the authorized officer of the Board. Intimation of intention to destroy or dispose of the molasses shall be given to the Board atleast 15 (fifteen) days in advance by registered post under intimation to the Sub-Regional officer and Regional officer of the Board under whose jurisdiction the factory is situated.
 - (v) The storage tanks shall be kept in good conditions all the year round with adequate maintenance. The tanks size and capacity per cm, height, total capacity in tonnes shall be displayed prominently near /on the tank.
 - (vi) The above conditions shall be in addition to and not in derogation of the provisions contained in the "Bombay Molasses Rules, 1955" and "Maharashtra Molasses Storage and Supply Regulation, 1965".
- 6) The Applicant shall provide Specific Water Pollution control system as per the conditions of EP Act, 1986 and rule made there under from time to time/ Environmental Clearance / CREP guidelines if applicable.

II) Conditions under Water (Prevention & Control of Pollution) CESS Act, 1977 as amended

The Applicant shall comply with the provisions of the Water (Prevention & Control of Pollution) Cess Act, 1977 and as amended, by installing water meters, filing water cess returns in Form-I and other provisions as contained in the said act.

Sr. No.	Purpose for water consumed	Water consumption quantity (CMD)
1.	Industrial Cooling, boiler feed etc.,	458
2.	Domestic purpose	40
3.	Processing whereby water gets polluted & pollutants are easily biodegradable	312
4.	Processing whereby water gets polluted & pollutants are not easily biodegradable and are toxic	—

Schedule-II

Terms & conditions for compliance of Air Pollution Control

1. As per your application, you have provided the Air pollution control (APC) system and also erected following stack (s) to observe the following fuel pattern-

Sr. No.	Stack Attached to	APC System	Height in meter	Type of Fuel	Quantity	S %	SO ₂ Kg/ Day
1.	Boiler (66 TPH)	ESP	75	Bagasse	566 MT/D	0.2 %	2264
2.	Boiler (40 TPH)	Wet Scrubber	60	Bagasse	432 MT/D	0.2 %	1728
3.	DG set of 500 KVA		4.0	HSD	20 Litrs./Hr.	1%	9.6

2. The Applicant shall provide ESP/ Bag filter/ Wet scrubber to the Bagasse fired boiler and Dust Collector to Sugar bagging section as an Air Pollution control equipments OR as per the conditions of EP Act, 1986 and rule made there under from time to time / Environmental Clearance / CREP guidelines.
3. The applicant shall operate and maintain above mentioned air pollution control system, so as to achieve the level of pollutants to the following standards:

Particulate matter	Not to exceed	150 mg/Nm ³
--------------------	---------------	------------------------

4. The Applicant shall obtain necessary prior permission for providing additional control equipment with necessary specifications and operation thereof or alteration or replacement/alteration well before its life come to an end or erection of new pollution control equipment.
5. The Board reserves its rights to vary all or any of the condition in the consent, if due to any technological improvement or otherwise such variation (including the change of any control equipment, other in whole or in part is necessary).



Schedule-III
Details of Bank Guarantees

Sr. No.	Consent (C to E/O/R)	Amt of BG Imposed	Submission Period	Purpose of BG	Compliance Period	Validity Date
1	C to R	Rs. 5.0 Lacs	To be extended	O & M for achieving consented standards of Effluent. O & M for achieving consented standards of Stack emission,	31.07.2016	30.11.2016



Schedule-IV
General Conditions

- 1) The applicant shall provide facility for collection of environmental samples and samples of trade and sewage effluents, air emissions and hazardous waste to the Board staff at the terminal or designated points and shall pay to the Board for the services rendered in this behalf.
- 2) Industry should monitor effluent quality, stack emissions and ambient air quality monthly.
- 3) The applicant shall provide ports in the chimney/(s) and facilities such as ladder, platform etc. for monitoring the air emissions and the same shall be open for inspection to/and for use of the Board's Staff. The chimney(s) vents attached to various sources of emission shall be designated by numbers such as S-1, S-2, etc. and these shall be painted/ displayed to facilitate identification.
- 4) Whenever due to any accident or other unforeseen act or even, such emissions occur or is apprehended to occur in excess of standards laid down, such information shall be forthwith Reported to Board, concerned Police Station, office of Directorate of Health Services, Department of Explosives, Inspectorate of Factories and Local Body. In case of failure of pollution control equipments, the production process connected to it shall be stopped.
- 5) The applicant shall provide an alternate electric power source sufficient to operate all pollution control facilities installed to maintain compliance with the terms and conditions of the consent. In the absence, the applicant shall stop, reduce or otherwise, control production to abide by terms and conditions of this consent.
- 6) The firm shall submit to this office, the 30th day of September every year, the Environmental Statement Report for the financial year ending 31st March in the prescribed Form-V as per the provisions of rule 14 of the Environment (Protection) (Second Amendment) Rules, 1992.
- 7) The industry shall recycle/reprocess/reuse/recover Hazardous Waste as per the provision contain in the HW (MH&TM) Rules 2008, which can be recycled /processed /reused /recovered and only waste which has to be incinerated shall go to incineration and waste which can be used for land filling and cannot be recycled/reprocessed etc should go for that purpose, in order to reduce load on incineration and landfill site/environment.
- 8) The industry should comply with the Hazardous Waste (M, H & TM) Rules, 2008 and submit the Annual Returns as per Rule 5(6) & 22(2) of Hazardous Waste (M, H & TM) Rules, 2008 for the preceding year April to March in Form-IV by 30th June of every year.
- 9) An inspection book shall be opened and made available to the Board's officers during their visit to the applicant.
- 10) The applicant shall make an application for renewal of the consent at least 60 days before the date of the expiry of the consent.**
- 11) Industry shall strictly comply with the Water (P&CP) Act, 1974, Air (P&CP) Act, 1981 and Environmental Protection Act, 1986 and industry specific standard under EP Rules 1986 which are available on MPCB website (www.mpcb.gov.in).
- 12) The industry shall constitute an Environmental cell with qualified staff/personnel/agency to see the day to day compliance of consent condition towards Environment Protection.
- 13) Separate drainage system shall be provided for collection of trade and sewage effluents. Terminal manholes shall be provided at the end of the collection system with arrangement for measuring the flow. No effluent shall be admitted in the pipes/sewers downstream of the terminal manholes. No effluent shall find its way other than in designed and provided collection system.
- 14) Neither storm water nor discharge from other premises shall be allowed to mix with the effluents from the factory.
- 15) The applicant shall install a separate meter showing the consumption of energy for operation of domestic and industrial effluent treatment plants and air pollution control system. A register showing consumption of chemicals used for treatment shall be maintained.
- 16) Conditions for D.G. Set
 - a) Noise from the D.G. Set should be controlled by providing an acoustic enclosure or by treating the room acoustically.
 - b) Industry should provide acoustic enclosure for control of noise. The acoustic enclosure/ acoustic treatment of the room should be designed for minimum 25 dB (A) insertion loss or for meeting

- the ambient noise standards, whichever is on higher side. A suitable exhaust muffler with insertion loss of 25 dB (A) shall also be provided. The measurement of insertion loss will be done at different points at 0.5 meters from acoustic enclosure/room and then average
- c) Industry should make efforts to bring down noise level due to DG set, outside industrial premises, within ambient noise requirements by proper siting and control measures.
 - d) Installation of DG Set must be strictly in compliance with recommendations of DG Set manufacturer.
 - e) A proper routine and preventive maintenance procedure for DG set should be set and followed in consultation with the DG manufacturer which would help to prevent noise levels of DG set from deteriorating with use.
 - f) D.G. Set shall be operated only in case of power failure.
 - g) The applicant should not cause any nuisance in the surrounding area due to operation of D.G. Set.
 - h) The applicant shall comply with the notification of MoEF dated 17.05.2002 regarding noise limit for generator sets run with diesel.
- 17) The industry should not cause any nuisance in surrounding area.
 - 18) The industry shall take adequate measures for control of noise levels from its own sources within the premises so as to maintain ambient air quality standard in respect of noise to less than 75 dB (A) during day time and 70 dB (A) during night time. Day time is reckoned in between 6 a.m. and 10 p.m. and night time is reckoned between 10 p.m. and 6 a.m.
 - 19) The applicant shall maintain good housekeeping.
 - 20) The applicant shall bring minimum 33% of the available open land under green coverage/ plantation. The applicant shall submit a yearly statement by 30th September every year on available open plot area, number of trees surviving as on 31st March of the year and number of trees planted by September end.
 - 21) The non-hazardous solid waste arising in the factory premises, sweepings, etc. be disposed of scientifically so as not to cause any nuisance / pollution. The applicant shall take necessary permissions from civic authorities for disposal of solid waste.
 - 22) The applicant shall not change or alter the quantity, quality, the rate of discharge, temperature or the mode of the effluent/emissions or hazardous wastes or control equipments provided for without previous written permission of the Board. The industry will not carry out any activity, for which this consent has not been granted/without prior consent of the Board.
 - 23) The industry shall ensure that fugitive emissions from the activity are controlled so as to maintain clean and safe environment in and around the factory premises.
 - 24) The industry shall submit quarterly statement in respect of industries obligation towards consent and pollution control compliance's duly supported with documentary evidences (format can downloaded from MPCB official site).
 - 25) The industry shall submit official e-mail address and any change will be duly informed to the MPCB.
 - 26) The industry shall achieve the National Ambient Air Quality standards prescribed vide Government of India, Notification dt. 16.11.2009 as amended.
 - 27) The Board reserves its rights to review plans, specifications or other data relating to plant setup for the treatment of waterworks for the purification thereof & the system for the disposal of sewage or trade effluent or in connection with the grant of any consent conditions. The Applicant shall obtain prior consent of the Board to take steps to establish the unit or establish any treatment and disposal system or an extension or addition thereto.
 - 28) The industry shall ensure replacement of pollution control system or its parts after expiry of its expected life as defined by manufacturer so as to ensure the compliance of standards and safety of the operation thereof.

-----0000-----

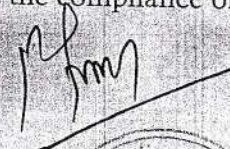

ENVIRONMENTAL MONITORING
AT
“Nira Bhima Sahakari Sakhar Karkhana Ltd”
At shahajinagar, Post-Redni,
Tal-Indapur, Dist-Pune



GESEC

TEST CERTIFICATE

Report No: GESEC/PRO/2019-20/05/55	Date of Report	13/05/2019
Client Name and Address: M/s. NiraBhimaSahakariSakharKarkhana Ltd. Shahajinagar ,Post-Redni, Tal-Indapur, Dist-Pune,Pin-413114.	Date of Sampling	06/05/2019
	Start Date of Analysis	07/05/2019
	End Date of Analysis	13/05/2019
	Sample Details	Ambient Air
	Sample Location	Khandobawadi
	Time of Sampling	10:10
Sample Collected By	Pragmatic Bio & Enviro	

Ambient Air Analysis Report

Sr. No.	Parameter	Result	Unit(s)	NAAQ Standards
1.	Ambient Temperature	32	°C	
2.	Dry Bulb Temperature	30	°C	
3.	Wet Bulb Temperature	27	°C	
4.	Relative Humidity	65	% RH	
5.	Sampling Duration	1440	Min	
6.	Sulphur Dioxide(SO ₂)	29.32	µg/M ³	≤ 80
7.	Oxides of Nitrogen(NO ₂)	37.36	µg/M ³	≤ 80
8.	Particulate Matter PM ₁₀	44.96	µg/M ³	≤ 100
9.	Particulate Matter PM _{2.5}	25.64	µg/M ³	≤ 60
10.	Carbon Monoxide (CO)	0.54	mg/M ³	≤ 04(1 Hr)

Remark-

➤ All above results are within National Ambient Air Quality standards.

ANALYZED BY-

[Signature]



AUTHORIZED SIGNATORY

[Signature]

Terms and conditions

- The report is refer only to the sample tested and not applies to the bulk.
- The results shown in this test report may differ based on various factors including temperature, humidity, pressure, retention time etc.
- The test report cannot be reproduced wholly or in part and cannot be used for promotional or publicity purpose without the written consent of laboratory, GESEC.
- Samples will be retained for a period of seven (7) days after completion of analysis. Longer retention periods can be arranged, on request of the customer.
- We strictly maintain the confidentiality of all test result of sample(s) collected by us/ supplied by customer and not revel to third party unless required by the statutory or legal requirement.
- MoEF approved Lab by Govt. of India. From date. 09/02/2017 to 08/02/2022.



GESEC

TEST CERTIFICATE

Report No: GESEC/PRO/2019-20/05/56	Date of Report	13/05/2019
Client Name and Address: M/s. NiraBhimaSahakariSakharKarkhana Ltd. Shahajinagar ,Post-Redni, Tal-Indapur, Dist-Pune, Pin-413114.	Date of Sampling	06/05/2019
	Start Date of Analysis	07/05/2019
	End Date of Analysis	13/05/2019
	Sample Details	Ambient Air
	Sample Location	Near Main Gate
	Time of Sampling	11:10
Sample Collected By	Pragmatic Bio & Enviro	

Ambient Air Analysis Report

Sr. No.	Parameter	Result	Unit(s)	NAAQ Standards
1.	Ambient Temperature	32	°C	
2.	Dry Bulb Temperature	32	°C	
3.	Wet Bulb Temperature	28	°C	
4.	Relative Humidity	69	% RH	
5.	Sampling Duration	1440	Min	
6.	Sulphur Dioxide(SO ₂)	16.95	µg/M ³	≤ 80
7.	Oxides of Nitrogen(NO ₂)	31.25	µg/M ³	≤ 80
8.	Particulate Matter PM ₁₀	40.23	µg/M ³	≤ 100
9.	Particulate Matter PM _{2.5}	15.63	µg/M ³	≤ 60
10.	Carbon Monoxide (CO)	1.45	mg/M ³	≤ 04(1 Hr)

Remark-

➤ All above results are within National Ambient Air Quality standards.

ANALYZED BY- 		AUTHORIZED SIGNATORY 
--	---	--

Terms and conditions

- The report is refer only to the sample tested and not applies to the bulk.
- The results shown in this test report may differ based on various factors including temperature, humidity, pressure, retention time etc.
- The test report cannot be reproduced wholly or in part and cannot be used for promotional or publicity purpose without the written consent of laboratory, GESEC.
- Samples will be retained for a period of seven (7) days after completion of analysis. Longer retention periods can be arranged, on request of the customer.
- We strictly maintain the confidentiality of all test result of sample(s) collected by us/ supplied by customer and not revel to third party unless required by the statutory or legal requirement.
- MoEF approved Lab by Govt. of India. From date. 09/02/2017 to 08/02/2022.



GESEC

TEST CERTIFICATE

Report No: GESEC/PRO/2019-20/05/57	Date of Report	13/05/2019
Client Name and Address: M/s. NiraBhimaSahakariSakharKarkhana Ltd. Shahajinagar ,Post-Redni, Tal-Indapur, Dist-Pune, Pin-413114.	Date of Sampling	06/05/2019
	Start Date of Analysis	07/05/2019
	End Date of Analysis	13/05/2019
	Sample Details	Ambient Air
	Sample Location	Devtekvasti
	Time of Sampling	12:10
Sample Collected By	Pragmatic Bio & Enviro	

Ambient Air Analysis Report

Sr. No.	Parameter	Result	Unit(s)	NAAQ Standards
1.	Ambient Temperature	32	°C	
2.	Dry Bulb Temperature	32	°C	
3.	Wet Bulb Temperature	25	°C	
4.	Relative Humidity	70	% RH	
5.	Sampling Duration	1440	Min	
6.	Sulphur Dioxide(SO ₂)	12.54	µg/M ³	≤ 80
7.	Oxides of Nitrogen(NO ₂)	21.45	µg/M ³	≤ 80
8.	Particulate Matter PM ₁₀	42.63	µg/M ³	≤ 100
9.	Particulate Matter PM _{2.5}	15.44	µg/M ³	≤ 60
10.	Carbon Monoxide (CO)	1.02	mg/M ³	≤ 04(1 Hr)

Remark-

➤ All above results are within National Ambient Air Quality standards.

ANALYZED BY-

Sholag

AUTHORIZED SIGNATORY

Hande



Terms and conditions

- The report is refer only to the sample tested and not applies to the bulk.
- The results shown in this test report may differ based on various factors including temperature, humidity, pressure, retention time etc.
- The test report cannot be reproduced wholly or in part and cannot be used for promotional or publicity purpose without the written consent of laboratory, GESEC.
- Samples will be retained for a period of seven (7) days after completion of analysis. Longer retention periods can be arranged, on request of the customer.
- We strictly maintain the confidentiality of all test result of sample(s) collected by us/ supplied by customer and not revel to third party unless required by the statutory or legal requirement.
- MoEF approved Lab by Govt. of India. From date. 09/02/2017 to 08/02/2022.

Recognised by Ministry of Environment, Forest & Climate Change (MoEF) Govt. of India and ISO/IEC 17025:2005 (NABL), ISO 9001:2015 and OHSAS 18001:2007 Certified Company

GESEC

TEST CERTIFICATE

Report No: GESEC/PRO/2019-20/05/58	Date of Report	13/05/2019
Client Name and Address: M/s. NiraBhimaSahakariSakharKarkhana Ltd. Shahajinagar ,Post-Redni, Tal-Indapur, Dist-Pune, Pin-413114.	Date of Sampling	06/05/2019
	Start Date of Analysis	07/05/2019
	End Date of Analysis	13/05/2019
	Sample Location	Boiler House
	Sample Details	Work zone Air
	Time of Sampling	1:20
Sample Collected By	Pragmatic Bio & Enviro	

Work Zone Air Analysis Report

Sr. No.	Parameter	Result	Unit(s)	The Factories Act 1948, standards
1.	Ambient Temperature	29	°C	
2.	Dry Bulb Temperature	29	°C	
3.	Wet Bulb Temperature	24	°C	
4.	Relative Humidity	48	% RH	
5.	Sampling Duration	15	Min	
6.	Sulphur Dioxide(SO ₂)	0.81	mg/M ³	≤ 10
7.	Oxides of Nitrogen(NO ₂)	0.75	mg/M ³	≤ 10
8.	Suspended Particulate Matter(SPM)	41.66	µg/M ³	N.S.
9.	Respirable Suspended Particulate Matter(RSPM)	23.66	µg/M ³	N.S.
10.	Carbon Monoxide (CO)	5.7	mg/M ³	≤ 440

Remark-

➤ All above results are well within The Factories Act, 1948 Standards.

ANALYZED BY-

AUTHORIZED SIGNATORY

Terms and conditions

- The report is refer only to the sample tested and not applies to the bulk.
- The results shown in this test report may differ based on various factors including temperature, humidity, pressure, retention time etc.
- The test report cannot be reproduced wholly or in part and cannot be used for promotional or publicity purpose without the written consent of laboratory, GESEC.
- Samples will be retained for a period of seven (7) days after completion of analysis. Longer retention periods can be arranged, on request of the customer.
- We strictly maintain the confidentiality of all test result of sample(s) collected by us/ supplied by customer and not revel to third party unless required by the statutory or legal requirement.
- MoEF approved Lab by Govt. of India. From date. 09/02/2017 to 08/02/2022.

Recognised by Ministry of Environment, Forest & Climate Change (MoEF) Govt. of India and ISO/IEC 17025:2005 (NABL), ISO 9001:2015 and OHSAS 18001:2007 Certified Company

GESEC

TEST CERTIFICATE

Report No: GESEC/PRO/2019-20/05/59	Date of Report	13/05/2019
Client Name and Address: M/s. NiraBhimaSahakariSakharKarkhana Ltd. Shahajinagar ,Post-Redni, Tal-Indapur, Dist-Pune, Pin-413114.	Date of Sampling	06/05/2019
	Start Date of Analysis	07/05/2019
	End Date of Analysis	13/05/2019
	Sample Location	Sugar Godown
	Sample Details	Work zone Air
	Time of Sampling	1:45
Sample Collected By	Pragmatic Bio & Enviro	

Work Zone Air Analysis Report

Sr. No.	Parameter	Result	Unit(s)	The Factories Act 1948, standards
1.	Ambient Temperature	26	°C	
2.	Dry Bulb Temperature	26	°C	
3.	Wet Bulb Temperature	28	°C	
4.	Relative Humidity	53	% RH	
5.	Sampling Duration	15	Min	
6.	Sulphur Dioxide(SO ₂)	0.65	mg/M ³	≤ 10
7.	Oxides of Nitrogen(NO ₂)	0.51	mg/M ³	≤ 10
8.	Suspended Particulate Matter(SPM)	49.96	µg/M ³	N.S.
9.	Respirable Suspended Particulate Matter(RSPM)	45.23	µg/M ³	N.S.
10.	Carbon Monoxide (CO)	5.66	mg/M ³	≤ 440

Remark-

➤ All above results are well within The Factories Act, 1948 Standards.

ANALYZED BY-

AUTHORIZED SIGNATORY



Terms and conditions

- The report is refer only to the sample tested and not applies to the bulk.
- The results shown in this test report may differ based on various factors including temperature, humidity, pressure, retention time etc.
- The test report cannot be reproduced wholly or in part and cannot be used for promotional or publicity purpose without the written consent of laboratory, GESEC.
- Samples will be retained for a period of seven (7) days after completion of analysis. Longer retention periods can be arranged, on request of the customer.
- We strictly maintain the confidentiality of all test result of sample(s) collected by us/ supplied by customer and not revel to third party unless required by the statutory or legal requirement.
- MoEF approved Lab by Govt. of India. From date. 09/02/2017 to 08/02/2022.

Recognised by Ministry of Environment, Forest & Climate Change (MoEF) Govt. of India and ISO/IEC 17025:2005 (NABL), ISO 9001:2015 and OHSAS 18001:2007 Certified Company

GESEC

TEST CERTIFICATE



Report No: GESEC/PRO/2019-20/05/60		Date of Report		18/11/2018
Client Name and Address: M/s. NiraBhimaSahakariSakharKarkhana Ltd. Shahajinagar ,Post-Redni, Tal-Indapur, Dist-Pune, Pin-413114.		Date of Sampling		14/11/2018
		Sample Details		Ambient Noise
Sample Collected By		Pragmatic Bio & Enviro		
Ambient Noise Report				
Sr. No.	Location	Result dB(A) Day	Result dB(A) Night	CPCB Standards dB(A)
1.	Khandobawadi	51.3	40.4	55/45
2.	Devtekvasti	51.9	43.1	
3.	Near Main Gate	52.9	41.2	
Remark-				
<ul style="list-style-type: none"> ➤ Maharashtra Pollution control board prescribed 55 dB(A) as an upper limit of noise level during day time and 45 dB(A) as an upper limit of noise level during at night time for residential Area. ➤ All aboveresults are within the prescribed limit by MPCB. 				
ANALYZED BY-		AUTHORIZED SIGNATORY		
		 		

Terms and conditions

1. The report is refer only to the sample tested and not applies to the bulk.
2. The results shown in this test report may differ based on various factors including temperature, humidity, pressure, retention time etc.
3. The test report cannot be reproduced wholly or in part and cannot be used for promotional or publicity purpose without the written consent of laboratory, GESEC.
4. Samples will be retained for a period of seven (7) days after completion of analysis. Longer retention periods can be arranged, on request of the customer.
5. We strictly maintain the confidentiality of all test result of sample(s) collected by us/ supplied by customer and not revel to third party unless required by the statutory or legal requirement.
6. MoEF approved Lab by Govt. of India. From date. 09/02/2017 to 08/02/2022.

GESEC

TEST CERTIFICATE

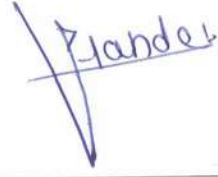
Report No: GESEC/PRO/2019-20/05/61		Date of Report		18/11/2018	
Client Name and Address: M/s. NiraBhimaSahakariSakharKarkhana Ltd. Shahajinagar ,Post-Redni, Tal-Indapur, Dist-Pune, Pin-413114.		Date of Sampling		14/11/2018	
		Sample Details		Work Zone Noise	
Sample Collected By		Pragmatic Bio & Enviro			
Work zone Noise Monitoring Report					
Sr. No.	Location	Result dB(A) Day	Result dB(A) Night	Unit	The Factories Act 1948, standards
1.	Sugar Godown	72.33	61.45	dB(A)	≤90
2.	Boiler House	83.66	74.21	dB(A)	
Remark-					
<ul style="list-style-type: none"> ➤ The Factories Act, 1948, has prescribed 90 dB (A) as an upper limit of noise level for 8 hours exposure. ➤ All aboveresults are within the prescribed limit by The Factories Act 1948. 					
ANALYZED BY-		AUTHORIZED SIGNATORY			
					

Terms and conditions

- The report is refer only to the sample tested and not applies to the bulk.
- The results shown in this test report may differ based on various factors including temperature, humidity, pressure, retention time etc.
- The test report cannot be reproduced wholly or in part and cannot be used for promotional or publicity purpose without the written consent of laboratory, GESEC.
- Samples will be retained for a period of seven (7) days after completion of analysis. Longer retention periods can be arranged, on request of the customer.
- We strictly maintain the confidentiality of all test result of sample(s) collected by us/ supplied by customer and not revel to third party unless required by the statutory or legal requirement.
- MoEF approved Lab by Govt. of India. From date. 09/02/2017 to 08/02/2022.

GESEC

TEST CERTIFICATE

Report No: GESEC/PRO/2019-20/05/62	Date of Report	13/05/2019
Client Name and Address: M/s. NiraBhimaSahakariSakharKarkhana Ltd. Shahajinagar ,Post-Redni, Tal-Indapur, Dist-Pune, Pin-413114.	Date of Sampling	06/05/2019
	Start Date of Analysis	07/05/2019
	End Date of Analysis	13/05/2019
	Sample Details	Within plant from source
	Nature of sample	Liquid
Sample Collected By	Pragmatic Bio & Enviro	

WATER ANALYSIS REPORT

Sr. No.	Parameter	Result	Limits as per Is 10500:2012	Unit(s)	Standard Method
Physical Parameter					
1	Turbidity	0.45	<1.0	NTU	IS: 3025 Part-10 (R.A : 2002)
2	TSS	9.9	N.S.	mg/lit	IS: 3025 Part-14 (R.A : 2006)
3	TDS	301.65	<500	mg/lit	IS: 3025 Part-16 (R.A : 2006)
4	Temperature	25.5	--	°C	IS: 3025 Part-15 (R.A : 2006)
5	Colour	<5	<5	Hazen	IS: 3025 Part-12 (R.A : 2006)
Chemical Parameter					
1	pH	7.5	6.5-8.5	--	IS: 3025 Part-11 (R.A : 2002)
2	E. Conductivity	405	N.S	µS/cm	IS: 3025 Part-14 (R.A : 2002)
3.	Total Hardness as CaCO ₃	152.4	<200	mg/lit	IS: 3025 Part-16 (R.A : 2006)
4	Total Alkalinity as CaCO ₃	125.4	<200	mg/lit	IS: 3025 Part-23 (R.A : 2003)
5	Chloride as Cl ⁻	16.5	250	mg/lit	IS: 3025 Part-32 (R.A : 2003)
6	Sulphate as SO ₄	5.4	<200	mg/lit	APHA :22 nd edition -(4500- SO ₄ ²⁻ E)
7	Residual chlorine	BDL	>0.2	mg/lit	APHA :22 nd edition -(4500-Cl B)
8	Nitrate as NO ₃	0.89	<45	mg/lit	APHA :22 nd edition -(4500- NO ₃ ²⁻ B)
9	Fluoride as F	0.05	<1.0	mg/lit	APHA :22 nd edition -(4500-F F)
10	Sulphide	N.D	N.S.	mg/lit	IS: 3025 Part-02 (2004)
11.	Phenolic Compound as	N.D	<0.001	mg/lit	IS: 3025 Part-43 (R.A : 2003)
12.	Dissolved Oxygen	3.4	N.S	mg/lit	IS: 3025 Part-02 (2004)
13.	Oil & Grease	BDL	N.S	mg/lit	IS: 3025 Part-02 (2004)
14.	Ammonical Nitrogen	0.013	N.S	mg/lit	IS: 3025 Part-02 (2004)
15.	Free Ammonia	N.D	N.S	mg/lit	IS: 3025 Part-02 (2004)
16.	Total Kjeldhal Nitrogen	0.022	N.S	mg/lit	IS: 3025 Part-02 (2004)

Terms and conditions

- The report is refer only to the sample tested and not applies to the bulk.
- The results shown in this test report may differ based on various factors including temperature, humidity, pressure, retention time etc.
- The test report cannot be reproduced wholly or in part and cannot be used for promotional or publicity purpose without the written consent of laboratory, GESEC.
- Samples will be retained for a period of seven (7) days after completion of analysis. Longer retention periods can be arranged, on request of the customer.
- We strictly maintain the confidentiality of all test result of sample(s) collected by us/ supplied by customer and not revel to third party unless required by the statutory or legal requirement.
- MoEF approved Lab by Govt. of India. From date. 09/02/2017 to 08/02/2022.





GESEC

Elemental Analysis					
1.	Aluminium as Al	N.D	<0.03	mg/lit	IS: 3025 Part-02 (2004)
2.	Arsenic as As	N.D	<0.01	mg/lit	IS: 3025 Part-02 (2004)
3.	Boron as B*	N.D	<0.5	mg/lit	IS: 3025 Part-02 (2004)
4.	Calcium as Ca	25.21	<75	mg/lit	IS: 3025 Part-02 (2004)
5.	Cadmium as Cd	BDL	<0.003	mg/lit	IS: 3025 Part-02 (2004)
6.	Iron as Fe	0.02	<0.3	mg/lit	IS: 3025 Part-02 (2004)
7.	Mercury as Hg	N.D	<0.001	mg/lit	IS: 3025 Part-02 (2004)
8.	Lead as Pb	BDL	<0.01	mg/lit	IS: 3025 Part-02 (2004)
9.	Selenium as Se	N.D	<0.01	mg/lit	IS: 3025 Part-02 (2004)
10.	Copper as Cu	BDL	<0.05	mg/lit	IS: 3025 Part-02 (2004)
11.	Manganese as Mn	BDL	<0.1	mg/lit	IS: 3025 Part-02 (2004)
12.	Magnesium as Mg	0.04	<30	mg/lit	IS: 3025 Part-02 (2004)
13.	Nickel	N.D	<0.2	mg/lit	IS: 3025 Part-02 (2004)
14.	Zinc as Zn	0.011	<5.0	mg/lit	IS: 3025 Part-02 (2004)
15.	Barium	N.D	<0.7	mg/lit	IS: 3025 Part-02 (2004)
16.	Silver	N.D	<0.1	mg/lit	IS: 3025 Part-02 (2004)
17.	Chromium as Cr	BDL	<0.05	mg/lit	IS: 3025 Part-02 (2004)
18.	Sodium as Na	6.6	N.S	mg/lit	IS: 3025 Part-02 (2004)
19.	Potassium As K	0.21	N.S	mg/lit	IS: 3025 Part-02 (2004)
20.	Cyanide as CN	N.D	<0.05	mg/lit	IS: 3025 Part-02 (2004)

Remark(s): All above results OfWater Sample is potable with respect to above parameters.

ANALYZED BY-

Shelae



AUTHORIZED SIGNATORY-

Hande!

Terms and conditions

1. The report is refer only to the sample tested and not applies to the bulk.
2. The results shown in this test report may differ based on various factors including temperature, humidity, pressure, retention time etc.
3. The test report cannot be reproduced wholly or in part and cannot be used for promotional or publicity purpose without the written consent of laboratory, GESEC.
4. Samples will be retained for a period of seven (7) days after completion of analysis. Longer retention periods can be arranged, on request of the customer.
5. We strictly maintain the confidentiality of all test result of sample(s) collected by us/ supplied by customer and not revel to third party unless required by the statutory or legal requirement.
6. MoEF approved Lab by Govt. of India. From date. 09/02/2017 to 08/02/2022.



GESEC

TEST CERTIFICATE

Report No: GESEC/PRO/2019-20/05/63	Date of Report	13/05/2019
Client Name and Address: M/s. NiraBhimaSahakariSakharKarkhana Ltd. Shahajinagar ,Post-Redni, Tal-Indapur, Dist-Pune, Pin-413114.	Date of Sampling	06/05/2019
	Start Date of Analysis	07/05/2019
	End Date of Analysis	13/05/2019
	Sample Details	Bhodani
	Nature of sample	Liquid
Sample Collected By	Pragmatic Bio & Enviro	

WATER ANALYSIS REPORT

Sr. No.	Parameter	Result	Limits as per Is 10500:2012	Unit(s)	Standard Method
Physical Parameter					
1	Turbidity	0.51	<1.0	NTU	IS: 3025 Part-10 (R.A : 2002)
2	TSS	15.4	N.S.	mg/lit	IS: 3025 Part-14 (R.A : 2006)
3	TDS	396	<500	mg/lit	IS: 3025 Part-16 (R.A : 2006)
4	Temperature	23.4	--	°C	IS: 3025 Part-15 (R.A : 2006)
5	Colour	<5	<5	Hazen	IS: 3025 Part-12 (R.A : 2006)
Chemical Parameter					
1	pH	7.5	6.5-8.5	--	IS: 3025 Part-11 (R.A : 2002)
2	E. Conductivity	461	N.S	µS/cm	IS: 3025 Part-14 (R.A : 2002)
3.	Total Hardness as CaCO ₃	162	<200	mg/lit	IS: 3025 Part-16 (R.A : 2006)
4	Total Alkalinity as CaCO ₃	115.2	<200	mg/lit	IS: 3025 Part-23 (R.A : 2003)
5	Chloride as Cl ⁻	21.4	250	mg/lit	IS: 3025 Part-32 (R.A : 2003)
6	Sulphate as SO ₄	25.6	<200	mg/lit	APHA :22 nd edition -(4500- SO ₄ ²⁻ E)
7	Residual chlorine	BDL	>0.2	mg/lit	APHA :22 nd edition -(4500-Cl B)
8	Nitrate as NO ₃	065	<45	mg/lit	APHA :22 nd edition -(4500- NO ₃ ²⁻ B)
9	Fluoride as F	0.02	<1.0	mg/lit	APHA :22 nd edition -(4500-F F)
10	Sulphide	N.D	N.S.	mg/lit	IS: 3025 Part-02 (2004)
11.	Phenolic Compound as	N.D	<0.001	mg/lit	IS: 3025 Part-43 (R.A : 2003)
12.	Dissolved Oxygen	3.4	N.S	mg/lit	IS: 3025 Part-02 (2004)
13.	Oil & Grease	BDL	N.S	mg/lit	IS: 3025 Part-02 (2004)
14.	Ammonical Nitrogen	0.01	N.S	mg/lit	IS: 3025 Part-02 (2004)
15.	Free Ammonia	N.D	N.S	mg/lit	IS: 3025 Part-02 (2004)
16.	Total Kjeldhal Nitrogen	0.04	N.S	mg/lit	IS: 3025 Part-02 (2004)
Elemental Analysis					

Terms and conditions

1. The report is refer only to the sample tested and not applies to the bulk.
2. The results shown in this test report may differ based on various factors including temperature, humidity, pressure, retention time etc.
3. The test report cannot be reproduced wholly or in part and cannot be used for promotional or publicity purpose without the written consent of laboratory.
4. Samples will be retained for a period of seven (7) days after completion of analysis. Longer retention periods can be arranged, on request of the customer.
5. We strictly maintain the confidentiality of all test result of sample(s) collected by us/ supplied by customer and not revel to third party unless required by the statutory or legal requirement.
6. MoEF approved Lab by Govt. of India. From date. 09/02/2017 to 08/02/2022.



GESEC

1.	Aluminium as Al	N.D	<0.03	mg/lit	IS: 3025 Part-02 (2004)
2.	Arsenic as As	N.D	<0.01	mg/lit	IS: 3025 Part-02 (2004)
3.	Boron as B*	N.D	<0.5	mg/lit	IS: 3025 Part-02 (2004)
4.	Calcium as Ca	35.2	<75	mg/lit	IS: 3025 Part-02 (2004)
5.	Cadmium as Cd	BDL	<0.003	mg/lit	IS: 3025 Part-02 (2004)
6.	Iron as Fe	0.032	<0.3	mg/lit	IS: 3025 Part-02 (2004)
7.	Mercury as Hg	N.D	<0.001	mg/lit	IS: 3025 Part-02 (2004)
8.	Lead as Pb	BDL	<0.01	mg/lit	IS: 3025 Part-02 (2004)
9.	Selenium as Se	N.D	<0.01	mg/lit	IS: 3025 Part-02 (2004)
10.	Copper as Cu	BDL	<0.05	mg/lit	IS: 3025 Part-02 (2004)
11.	Manganese as Mn	BDL	<0.1	mg/lit	IS: 3025 Part-02 (2004)
12.	Magnesium as Mg	0.009	<30	mg/lit	IS: 3025 Part-02 (2004)
13.	Nickel	N.D	<0.2	mg/lit	IS: 3025 Part-02 (2004)
14.	Zinc as Zn	0.04	<5.0	mg/lit	IS: 3025 Part-02 (2004)
15.	Barium	N.D	<0.7	mg/lit	IS: 3025 Part-02 (2004)
16.	Silver	N.D	<0.1	mg/lit	IS: 3025 Part-02 (2004)
17.	Chromium as Cr	BDL	<0.05	mg/lit	IS: 3025 Part-02 (2004)
18.	Sodium as Na	6.7	N.S	mg/lit	IS: 3025 Part-02 (2004)
19.	Potassium As K	1.45	N.S	mg/lit	IS: 3025 Part-02 (2004)
20.	Cyanide as CN	N.D	<0.05	mg/lit	IS: 3025 Part-02 (2004)

Remark(s): All above resultsof Water Sample is potable with respect to above parameters.

ANALYZED BY-



AUTHORIZED SIGNATORY-

Terms and conditions

1. The report is refer only to the sample tested and not applies to the bulk.
2. The results shown in this test report may differ based on various factors including temperature, humidity, pressure, retention time etc.
3. The test report cannot be reproduced wholly or in part and cannot be used for promotional or publicity purpose without the written consent of laboratory, GESEC.
4. Samples will be retained for a period of seven (7) days after completion of analysis. Longer retention periods can be arranged, on request of the customer.
5. We strictly maintain the confidentiality of all test result of sample(s) collected by us/ supplied by customer and not revel to third party unless required by the statutory or legal requirement.
6. MoEF approved Lab by Govt. of India. From date. 09/02/2017 to 08/02/2022.

GESEC

TEST CERTIFICATE

Report No: GESEC/PRO/2019-20/05/64	Date of Report	13/05/2019
Client Name and Address: M/s. NiraBhimaSahakariSakharKarkhana Ltd. Shahajinagar ,Post-Redni, Tal-Indapur, Dist-Pune, Pin-413114.	Date of Sampling	06/05/2019
	Start Date of Analysis	07/05/2019
	End Date of Analysis	13/05/2019
	Sample Details	Shahajinagar
	Nature of sample	Liquid
Sample Collected By	Pragmatic Bio & Enviro	

WATER ANALYSIS REPORT

Sr. No.	Parameter	Result	Limits as per Is 10500:2012	Unit(s)	Standard Method
Physical Parameter					
1	Turbidity	0.65	<1.0	NTU	IS: 3025 Part-10 (R.A : 2002)
2	TSS	17.4	N.S.	mg/lit	IS: 3025 Part-14 (R.A : 2006)
3	TDS	400	<500	mg/lit	IS: 3025 Part-16 (R.A : 2006)
4	Temperature	26.3	--	°C	IS: 3025 Part-15 (R.A : 2006)
5	Colour	<5	<5	Hazen	IS: 3025 Part-12 (R.A : 2006)
Chemical Parameter					
1	pH	7.7	6.5-8.5	--	IS: 3025 Part-11 (R.A : 2002)
2	E. Conductivity	615	N.S	µS/cm	IS: 3025 Part-14 (R.A : 2002)
3.	Total Hardness as CaCO ₃	162.3	<200	mg/lit	IS: 3025 Part-16 (R.A : 2006)
4	Total Alkalinity as CaCO ₃	145.2	<200	mg/lit	IS: 3025 Part-23 (R.A : 2003)
5	Chloride as Cl ⁻	26.4	250	mg/lit	IS: 3025 Part-32 (R.A : 2003)
6	Sulphate as SO ₄	37.2	<200	mg/lit	APHA :22 nd edition -(4500- SO ₄ ²⁻ E)
7	Residual chlorine	BDL	>0.2	mg/lit	APHA :22 nd edition -(4500-Cl B)
8	Nitrate as NO ₃	0.40	<45	mg/lit	APHA :22 nd edition -(4500- NO ₃ ²⁻ B)
9	Fluoride as F	0.065	<1.0	mg/lit	APHA :22 nd edition -(4500-F F)
10	Sulphide	N.D	N.S.	mg/lit	IS: 3025 Part-02 (2004)
11.	Phenolic Compound as	N.D	<0.001	mg/lit	IS: 3025 Part-43 (R.A : 2003)
12.	Dissolved Oxygen	2.9	N.S	mg/lit	IS: 3025 Part-02 (2004)
13.	Oil & Grease	BDL	N.S	mg/lit	IS: 3025 Part-02 (2004)
14.	Ammonical Nitrogen	0.014	N.S	mg/lit	IS: 3025 Part-02 (2004)
15.	Free Ammonia	N.D	N.S	mg/lit	IS: 3025 Part-02 (2004)
16.	Total Kjeldhal Nitrogen	0.02	N.S	mg/lit	IS: 3025 Part-02 (2004)
Elemental Analysis					

Terms and conditions

- The report is refer only to the sample tested and not applies to the bulk.
- The results shown in this test report may differ based on various factors including temperature, humidity, pressure, retention time etc.
- The test report cannot be reproduced wholly or in part and cannot be used for promotional or publicity purpose without the written consent of laboratory, GESEC.
- Samples will be retained for a period of seven (7) days after completion of analysis. Longer retention periods can be arranged, on request of the customer.
- We strictly maintain the confidentiality of all test result of sample(s) collected by us/ supplied by customer and not revel to third party unless required by the statutory or legal requirement.
- MoEF approved Lab by Govt. of India. From date. 09/02/2017 to 08/02/2022.



Recognised by Ministry of Environment, Forest & Climate Change (MoEF) Govt. of India and ISO/IEC 17025:2005 (NABL), ISO 9001:2015 and OHSAS 18001:2007 Certified Company

GESEC

1.	Aluminium as Al	N.D	<0.03	mg/lit	IS: 3025 Part-02 (2004)
2.	Arsenic as As	N.D	<0.01	mg/lit	IS: 3025 Part-02 (2004)
3.	Boron as B*	N.D	<0.5	mg/lit	IS: 3025 Part-02 (2004)
4.	Calcium as Ca	27.4	<75	mg/lit	IS: 3025 Part-02 (2004)
5.	Cadmium as Cd	BDL	<0.003	mg/lit	IS: 3025 Part-02 (2004)
6.	Iron as Fe	0.017	<0.3	mg/lit	IS: 3025 Part-02 (2004)
7.	Mercury as Hg	N.D	<0.001	mg/lit	IS: 3025 Part-02 (2004)
8.	Lead as Pb	BDL	<0.01	mg/lit	IS: 3025 Part-02 (2004)
9.	Selenium as Se	N.D	<0.01	mg/lit	IS: 3025 Part-02 (2004)
10.	Copper as Cu	BDL	<0.05	mg/lit	IS: 3025 Part-02 (2004)
11.	Manganese as Mn	BDL	<0.1	mg/lit	IS: 3025 Part-02 (2004)
12.	Magnesium as Mg	0.004	<30	mg/lit	IS: 3025 Part-02 (2004)
13.	Nickel	N.D	<0.2	mg/lit	IS: 3025 Part-02 (2004)
14.	Zinc as Zn	0.012	<5.0	mg/lit	IS: 3025 Part-02 (2004)
15.	Barium	N.D	<0.7	mg/lit	IS: 3025 Part-02 (2004)
16.	Silver	N.D	<0.1	mg/lit	IS: 3025 Part-02 (2004)
17.	Chromium as Cr	BDL	<0.05	mg/lit	IS: 3025 Part-02 (2004)
18.	Sodium as Na	12.4	N.S	mg/lit	IS: 3025 Part-02 (2004)
19.	Potassium As K	N.D	N.S	mg/lit	IS: 3025 Part-02 (2004)
20.	Cyanide as CN	N.D	<0.05	mg/lit	IS: 3025 Part-02 (2004)

Remark(s): All above results of Water Sample is potable with respect to above parameters.

ANALYZED BY-



AUTHORIZED SIGNATORY-



Terms and conditions

- The report is refer only to the sample tested and not applies to the bulk.
- The results shown in this test report may differ based on various factors including temperature, humidity, pressure, retention time etc.
- The test report cannot be reproduced wholly or in part and cannot be used for promotional or publicity purpose without the written consent of laboratory, GESEC.
- Samples will be retained for a period of seven (7) days after completion of analysis. Longer retention periods can be arranged, on request of the customer.
- We strictly maintain the confidentiality of all test result of sample(s) collected by us/ supplied by customer and not revel to third party unless required by the statutory or legal requirement.
- MoEF approved Lab by Govt. of India. From date. 09/02/2017 to 08/02/2022.



GESEC

TEST CERTIFICATE

Report No: GESEC/PRO/2019-20/05/65	Date of Report	13/05/2019
Client Name and Address: M/s. NiraBhimaSahakariSakharKarkhana Ltd. Shahajinagar ,Post-Redni, Tal-Indapur, Dist-Pune, Pin-413114.	Date of Sampling	06/05/2019
	Start Date of Analysis	07/05/2019
	End Date of Analysis	13/05/2019
	Sample Details	Project side
	Nature of sample	Solid
Sample Collected By	Pragmatic Bio & Enviro	

SOIL ANALYSIS REPORT

Sr. No.	Parameter	Result	Unit(s)	Standard Method
Physical Parameter				
1.	Moisture Content	16.0	percent	IS : 2720
2.	Water Holding Capacity	54.3	percent	IS : 2720
3.	Sand	23.1	percent	IS : 2720
	Slit	44.6		
	Clay	26.1		
	Color	Brown	---	C.A. Black, American Society of Agronomy 5 th Edition, 65-15800
Chemical Parameter				
1.	pH (1:5 Suspension)	8.4	--	C.A. Black, American Society of Agronomy 5 th Edition, 65-15800
2.	Conductivity	72.0	µS/cm	C.A. Black, American Society of Agronomy 5 th Edition, 65-15800
3.	Organic Matter	2.1	percent	C.A. Black, American Society of Agronomy 5 th Edition, 65-15800
4.	Total Kjeldahl Nitrogen (as N)	0.004	percent	C.A. Black, American Society of Agronomy 5 th Edition, 65-15800
5.	Total Nitrogen	371.2	mg/kg	C.A. Black, American Society of Agronomy 5 th Edition, 65-15800
6.	Free Ammoniacal Nitrogen	BDL	%	
Elemental Testing				
1.	Potassium as k	0.065	%	APHA (Edition 22 nd) 3120 B
2.	Phosphorous	0.063	%	APHA (Edition 22 nd) 3120 B
3.	Calcium as Ca	2.12	%	APHA (Edition 22 nd) 3120 B
4.	Magnesium as Mg	0.43	%	APHA (Edition 22 nd) 3120 B

Terms and conditions

- The report is refer only to the sample tested and not applies to the bulk.
- The results shown in this test report may differ based on various factors including temperature, humidity, pressure, retention time etc.
- The test report cannot be reproduced wholly or in part and cannot be used for promotional or publicity purpose without the written consent of laboratory, GESEC.
- Samples will be retained for a period of seven (7) days after completion of analysis. Longer retention periods can be arranged, on request of the customer.
- We strictly maintain the confidentiality of all test result of sample(s) collected by us/ supplied by customer and not revel to third party unless required by the statutory or legal requirement.
- MoEF approved Lab by Govt. of India. From date. 09/02/2017 to 08/02/2022.





GESEC

5.	Iron as Fe	BDL	ppm	APHA (Edition 22 nd) 3120 B
6.	Copper as Cu	0.20	ppm	
7.	Chromium	BDL	ppm	APHA (Edition 22 nd) 3120 B
8.	Cadmium as Cd	BDL	ppm	APHA (Edition 22 nd) 3120 B
9.	Lead as Pb	BDL	%	APHA (Edition 22 nd) 3120 B
10.	Manganese as Mn	0.34	ppm	APHA (Edition 22 nd) 3120 B
11.	Zinc as Zn	0.45	ppm	APHA (Edition 22 nd) 3120 B
12.	Total Carbon	1.8	%	C.A. Black, American Society of Agronomy 5 th Edition, 65-15800
13.	Boron	BDL	ppm	APHA (Edition 22 nd) 3120 B
14.	Humic Acid	0.15	%	
15.	Molybdenum	BDL	ppm	APHA (Edition 22 nd) 3120 B
ANALYZED BY-		AUTHORIZED SIGNATORY		



Terms and conditions

1. The report is refer only to the sample tested and not applies to the bulk.
2. The results shown in this test report may differ based on various factors including temperature, humidity, pressure, retention time etc.
3. The test report cannot be reproduced wholly or in part and cannot be used for promotional or publicity purpose without the written consent of laboratory, GESEC.
4. Samples will be retained for a period of seven (7) days after completion of analysis. Longer retention periods can be arranged, on request of the customer.
5. We strictly maintain the confidentiality of all test result of sample(s) collected by us/ supplied by customer and not revel to third party unless required by the statutory or legal requirement.
6. MoEF approved Lab by Govt. of India. From date. 09/02/2017 to 08/02/2022.



GESEC

TEST CERTIFICATE

Report No: GESEC/PRO/2019-20/05/66	Date of Report	13/05/2019
Client Name and Address: M/s. NiraBhimaSahakariSakharKarkhana Ltd. Shahajinagar ,Post-Redni, Tal-Indapur, Dist-Pune, Pin-413114.	Date of Sampling	06/05/2019
	Start Date of Analysis	07/05/2019
	End Date of Analysis	13/05/2019
	Sample Details	Devtekvasti
	Nature of sample	Solid
Sample Collected By	Pragmatic Bio & Enviro	

SOIL ANALYSIS REPORT

Sr. No.	Parameter	Result	Unit(s)	Standard Method
Physical Parameter				
1.	Moisture Content	22.1	percent	IS : 2720
2.	Water Holding Capacity	49.2	percent	IS : 2720
3.	Sand	35	percent	IS : 2720
	Slit	47		
	Clay	27		
	Color	Brown	---	C.A. Black, American Society of Agronomy 5 th Edition, 65-15800
Chemical Parameter				
1.	pH (1:5 Suspension)	7.5	--	C.A. Black, American Society of Agronomy 5 th Edition, 65-15800
2.	Conductivity	75.0	μS/cm	C.A. Black, American Society of Agronomy 5 th Edition, 65-15800
3.	Organic Matter	3.4	percent	C.A. Black, American Society of Agronomy 5 th Edition, 65-15800
4.	Total Kjeldahl Nitrogen (as N)	0.04	percent	C.A. Black, American Society of Agronomy 5 th Edition, 65-15800
5.	Free Ammoniacal Nitrogen	BDL	%	
Elemental Testing				
1.	Potassium as k	0.04	%	APHA (Edition 22 nd) 3120 B
2.	Phosphorous	0.034	%	APHA (Edition 22 nd) 3120 B
3.	Calcium as Ca	2.52	%	APHA (Edition 22 nd) 3120 B
4.	Magnesium as Mg	0.57	%	APHA (Edition 22 nd) 3120 B
5.	Iron as Fe	25.6	ppm	APHA (Edition 22 nd) 3120 B
6.	Copper as Cu	0.41	ppm	APHA (Edition 22 nd) 3120 B

Terms and conditions

- The report is refer only to the sample tested and not applies to the bulk.
- The results shown in this test report may differ based on various factors including temperature, humidity, pressure, retention time etc.
- The test report cannot be reproduced wholly or in part and cannot be used for promotional or publicity purpose without the written consent of laboratory, GESEC.
- Samples will be retained for a period of seven (7) days after completion of analysis. Longer retention periods can be arranged, on request of the customer.
- We strictly maintain the confidentiality of all test result of sample(s) collected by us/ supplied by customer and not revel to third party unless required by the statutory or legal requirement.
- MoEF approved Lab by Govt. of India. From date. 09/02/2017 to 08/02/2022.





GESEC

7.	Chromium	BDL	ppm	APHA (Edition 22 nd) 3120 B
8.	Cadmium as Cd	BDL	ppm	APHA (Edition 22 nd) 3120 B
9.	Lead as Pb	BDL	%	APHA (Edition 22 nd) 3120 B
10.	Manganese as Mn	0.51	ppm	APHA (Edition 22 nd) 3120 B
11.	Zinc as Zn	0.46	ppm	APHA (Edition 22 nd) 3120 B
12.	Total Carbon	3.1	%	C.A. Black, American Society of Agronomy 5 th Edition, 65-15800
13.	Boron	BDL	ppm	APHA (Edition 22 nd) 3120 B
14.	Humic Acid	0.1	%	
15.	Molybdenum	BDL	ppm	APHA (Edition 22 nd) 3120 B
ANALYZED BY- 		 AUTHORIZED SIGNATORY 		

Terms and conditions

1. The report is refer only to the sample tested and not applies to the bulk.
2. The results shown in this test report may differ based on various factors including temperature, humidity, pressure, retention time etc.
3. The test report cannot be reproduced wholly or in part and cannot be used for promotional or publicity purpose without the written consent of laboratory, GESEC.
4. Samples will be retained for a period of seven (7) days after completion of analysis. Longer retention periods can be arranged, on request of the customer.
5. We strictly maintain the confidentiality of all test result of sample(s) collected by us/ supplied by customer and not revel to third party unless required by the statutory or legal requirement.
6. MoEF approved Lab by Govt. of India. From date. 09/02/2017 to 08/02/2022.



GESEC

TEST CERTIFICATE

Report No: GESEC/PRO/2019-20/05/67	Date of Report	13/05/2019
Client Name and Address: M/s. NiraBhimaSahakariSakharKarkhana Ltd. Shahajinagar ,Post-Redni, Tal-Indapur, Dist-Pune, Pin-413114.	Date of Sampling	06/05/2019
	Start Date of Analysis	07/05/2019
	End Date of Analysis	13/05/2019
	Sample Location	Sugar Stack
	Sample Details	Stack
	Time of Sampling	2:20
Sample Collected By	Pragmatic Bio & Enviro	

Source Emission Analysis Report

Sr. No.	Parameter	Result	Unit(s)	Limits As Per MPCB Consent	Standard Method
1.	Material of Stack	MS	--		
2.	Stack Height from G.L.	66.0	Mtr.		
3.	Type of Stack	Round	--		
4.	Sampling Duration	30	Min.		
5.	Flue Gas Temperature	418	°K		
6.	Differential Pressure	1.3	mmWG		
7.	Velocity	4.42	M/s		
8.	Dimensions of Stack	1.89	Mtr.		
9.	Stack Area	2.804	M ²		
10.	Gas Volume	31858.14	NM ³ /Hr		
11.	Total Particulate Matter(TPM)	108.2	mg/NM ³	≤ 150	IS:11255(Part 1)-1985
12.	Sulphur Dioxide (SO ₂)	51.2	mg/NM ³	--	IS:11255(Part 2)-1985
13.	Sulphur Dioxide (SO ₂)	44.21	Kg/day	--	
14.	Oxide of Nitrogen (NO _x)	185.2	mg/NM ³	--	IS:11255(Part 7)-1985
15.	Carbon Monoxide (CO)	14.1	mg/NM ³	--	Manual Instruction

Remark(s):

- All above results are well within MPCB Limit.

ANALYZED BY-

Shalae



AUTHORIZED SIGNATORY-

Shalae

Terms and conditions

- The report is refer only to the sample tested and not applies to the bulk.
- The results shown in this test report may differ based on various factors including temperature, humidity, pressure, retention time etc.
- The test report cannot be reproduced wholly or in part and cannot be used for promotional or publicity purpose without the written consent of laboratory, GESEC.
- Samples will be retained for a period of seven (7) days after completion of analysis. Longer retention periods can be arranged, on request of the customer.
- We strictly maintain the confidentiality of all test result of sample(s) collected by us/ supplied by customer and not revel to third party unless required by the statutory or legal requirement.
- MoEF approved Lab by Govt. of India. From date. 09/02/2017 to 08/02/2022.



GESEC

TEST CERTIFICATE

Report No: GESEC/PRO/2019-20/05/68	Date of Report	13/05/2019
Client Name and Address: M/s. NiraBhimaSahakariSakharKarkhana Ltd. Shahajinagar ,Post-Redni, Tal-Indapur, Dist-Pune, Pin-413114.	Date of Sampling	06/05/2019
	Start Date of Analysis	07/05/2019
	End Date of Analysis	13/05/2019
	Sample Location	Cogen Stack
	Sample Details	Stack
	Time of Sampling	3:10
Sample Collected By	Pragmatic Bio & Enviro	

Source Emission Analysis Report

Sr. No.	Parameter	Result	Unit(s)	Limits As Per MPCB Consent	Standard Method
1.	Material of Stack	MS	--		
2.	Stack Height from G.L.	75.0	Mtr.		
3.	Type of Stack	Round	--		
4.	Sampling Duration	30	Min.		
5.	Flue Gas Temperature	420	°K		
6.	Differential Pressure	1.3	mmWG		
7.	Velocity	4.43	M/s		
8.	Dimensions of Stack	1.9	Mtr.		
9.	Stack Area	2.833	M ²		
10.	Gas Volume	32119.42	NM ³ /Hr		
11.	Total Particulate Matter(TPM)	90.3	mg/NM ³	≤ 150	IS:11255(Part 1)-1985
12.	Sulphur Dioxide (SO ₂)	51.32	mg/NM ³	--	IS:11255(Part 2)-1985
13.	Sulphur Dioxide (SO ₂)	40.47	Kg/day	--	
14.	Oxide of Nitrogen (NO _x)	190.5	mg/NM ³	--	IS:11255(Part 7)-1985
15.	Carbon Monoxide (CO)	16.3	mg/NM ³	--	Manual Instruction

Remark(s):

- All above results are well within MPCB Limit

ANALYZED BY-

@heloe

AUTHORIZED SIGNATORY-

P. Habde!



Terms and conditions

- The report is refer only to the sample tested and not applies to the bulk.
- The results shown in this test report may differ based on various factors including temperature, humidity, pressure, retention time etc.
- The test report cannot be reproduced wholly or in part and cannot be used for promotional or publicity purpose without the written consent of laboratory, GESEC.
- Samples will be retained for a period of seven (7) days after completion of analysis. Longer retention periods can be arranged, on request of the customer.
- We strictly maintain the confidentiality of all test result of sample(s) collected by us/ supplied by customer and not revel to third party unless required by the statutory or legal requirement.
- MoEF approved Lab by Govt. of India. From date. 09/02/2017 to 08/02/2022.

*A Copy of EC Letter (SEAC-2012/CR-177/TC-2)
For
“Nira Bhima Sahakari Sakhar Karkhana Ltd”
At shahajinagar, Post-Redni,
Tal-Indapur, Dist-Pune*

Government of Maharashtra

SEAC-2012/CR-177/TC2
Environment department
Room No. 217, 2nd floor,
Mantralaya Annexe,
Mumbai- 400 032.
Dated: 21st January, 2014

To,
M/s. Nira Bhima Sahakari Sakhar Karkhana Ltd
Shahajinagar, Post- Redni,
Tal. Indapur, Dist.-Pune- 4131114

Subject: Environmental clearance for proposed 18 MW Bagasse based Co-generation power plant at Nira Bhima Sahakari Sakhar Karkhana Ltd. Shahajinagar, Post-Redni, Tal. Indapur, Dist. Pune by M/s. Nira Bhima Sahakari Sakhar Karkhana Ltd

Sir,

This has reference to your communication on the above mentioned subject. The proposal was considered as per the EIA Notification, 2006, by the State Level Expert Appraisal Committee-I, Maharashtra in its 72nd meeting and decided to recommend the project for prior environmental clearance to SEIAA. Information submitted by you has been considered by State Level Environment Impact Assessment Authority in its 63rd Meeting.

2- It is noted that the proposal is for grant of Environmental Clearance Proposed 18 MW Bagasse based Co-generation power plant at Nira Bhima Sahakari Sakhar Karkhana Ltd., Shahajinagar, Post-Redni, Tal. Indapur, Dist. Pune. SEAC considered the project under screening category I (d), B1 of EIA Notification, 2006.

Brief Information of the project submitted by Project Proponent is as:

Name of Project	18 MW Bagasse Based Co-generation Power Plant by Nira Bhima Sahakari Sakhar Karkhana Ltd. (NBSSKL)	
Project Proponent	M/s. Nira Bhima Sahakari Sakhar Karkhana Ltd. (NBSSKL)	
Consultant	MITCON Consultancy & Engineering Services Ltd.	
New Project	New Project	
Area Details	Total plot area (Acre.): 100 Built up area (Acre.): 11	
Estimated capital cost of the Project (including cost for land, building, plant and machinery separately)	Total Project Cost	Cogen Power (Rs. in Lakh)
	Land & Site Development	12.00
	Civil works & Buildings	482.82
	Indigenous Plant and Machinery	6780.62
	Preliminary & Pre-Op. Expenses	571.35
	Contingencies	19.19
Margin Money	40	

		Miscellaneous Fixed Assests	120		
		Power Evacuation arrangement	740.80		
		Supervision Charges for Synchronizing	14.92		
		Total	8781.7		
Location details of the project :	Latitude : 17°59'29.94"N Longitude : 74°56'42.45"E Location : Gut No. 340,341,344,345,346,347,348 Shahajinagar, Post- Redni, Tal. Indapur, Dist.-Pune. Pin-413114 Elevation above Mean Sea Level: 525 meter				
Distance from Protected Areas	There are no Protected areas / Critically polluted areas / Eco-Sensitive areas/ inter-state boundaries within 10 Km radial area				
Raw materials (including process chemicals, catalysts, & additives).	List of raw materials to be used	Physical and chemical nature of raw material	Quantity (tonnes/ year) full production capacity	Source of materials	Means of transportation (Source to storage site) with justification
	Bagasse	Fibrous material	Season (160 days) : 152564MT Off-season (69 Days): 32493 MT	Existing Sugar Factory (NBSSKI.)	By conveyor belt with enclosed sheet & pipelines
	Biogas	Gas	Season :1.475 TPII Off-season :1.475 TPII		
Production details	Name of Products, By products and Intermediate Products		Existing (T/Year)	Proposed activity (new/modernization/expansion) (T/Year)	Total (T/Year)
	Main Products: (Power)	Season (160 Days)	0	18 MW	18MW
		Off-Season (69Days)	0	12 MW	12 MW
	By-Products Intermediate Products: Ash	Season (160 Days)	0	3051 MT	3051 MT
		Off-Season (69 Days)	0	650 MT	650 MT
Process details / manufacturing details	In power generation scheme, chemical energy of fuel is first converted into thermal energy (during combustion), which is then converted into mechanical energy (through a turbine) and finally into electrical energy (through a generator).				
Rain Water Harvesting (RWH)	In the factory premises roof top area will be determined and subsequently rain water harvesting potential will be calculated. However detailed design and engineering of the RWH system will be undertaken during implementation stage.				
Total Water Requirement	Total water requirement: Fresh water (CMD) : Season (160 Days) :893 Off- Season (69 Days) : 1009				

		& Source: Bhima River			
		Use of the water:			
		Particulars	Season (CMD)	Off-Season (CMD)	
		Process	30	25	
		Cooling water	464	690	
		DM Water	398	293	
		Dust Suppression	60*	61*	
		Drinking	1	1	
		Green belt	86*	80	
		Fire service	13	13	
		Others	2	1	
		*Treated water reused			
Storm water drainage	Proper storm water drainage line will be provided to maintain the natural flow of storm water				
Sewage generation and treatment	Amount of sewage generation (CMD) :3 Proposed treatment for the sewage : Septic tanks followed by Soak Pits Capacity of the STP (CMD) (If applicable): NA. all sewage will be treated in ETP				
Effluent characteristic	All the effluent characteristic will be prescribed as per MPCB, Norms				
ETP details	Existing ETP having capacity 700 m ³ /day. NBSSKL has already modernized existing ETP.				
Disposal of the ETP sludge (If applicable)	After treatment in ETP generated sludge will be used for gardening purpose				
Solid waste Management	Sr. No	Source	Qty (TPM)	Form (Sludge / Dry / Slurry etc.)	Composition
	1.	Raw water treatment plant	--	--	--
	2.	ETP	8 MT (18 MW season operation-160days and 3MT (12 MW off season operation)	Sludge	---
	3.	Process	Ash-3051MT (18 MW season operation-160days and 650MT (12 MW off season operation)	Dry	potash
	4.	Spent Catalyst	--	--	--

	5.	Oily Sludge	--	--	--	
	6.	Others like Battery waste, e waste etc (Pl. Specify)	--	--	--	
Atmospheric Emissions (Flue gas characteristics SPM, SO ₂ , NO _x , CO, etc.)	Sr. No.	Pollutant	Source of Emission	Emission rate (kg/hr)	Concentration in flue gas (g/sec)	
	1	SPM	Stack	0.477	3.1	
	2	SO ₂	Stack	39.73	11	
	3	NO _x	Stack	Concentration in flue gas will be 100 mg/Nm ³		
	4	CO	Stack	NA	NA	
Stack emission Details:						
	Plant Section & units	Stack No.	Height from ground level (m)	Internal Diameter (Top)(m)	Emission Rate (kg/hr)	Temp. of Exhaust Gases (°C)
	66 TPH Boiler	1 st	75	3.6	0.29	150
	40 TPH Boiler	2 nd	60	3.5	11.16	
Emission Standard	As per CPCB, MPCB Norms					
Ambient Air Quality Data						
	Pollutant	Permissible Standard µg/m ³	Proposed/ Resultant Concentration (in µg/m ³)	Remarks		
	PM ₁₀	100	27.22	Due to proposed activity there is increase in pollution activity it will be mitigate by providing pollution control equipments such as ESP & dust suppression method & by developing green belt around the factory and within the premises		
	SO ₂	80	31.9			
	NO _x	80	29.3			

Details of Fuel to be used:	Fuel	Daily Consumption (TPD/KLD)		Calorific value (Kcals /kg)	% Ash	% Sulphur																				
		Existing	Proposed																							
	Bagasse		Season:95 4 Off- Season: 471	2250	2	0.05																				
Source of fuel: Existing Sugar Unit having capacity 2500-3500 TCD Mode of transportation of fuel to site: Conveyor Belts																										
Energy	Power supply: Existing power requirement: } Season : 6027 KW Proposed power requirement: } Off-Season : 1639 KW DG sets: Number and capacity DG sets to be used (existing and proposed) Details of the non-conventional renewable energy proposed to be used : Yes Bagasse will be used : Season (160 Days) - 152564 MT Off-Season (69 Days) - 32493MT Biogas : Season (160 Days) - 1.475 TPH Off-Season (69 Days) - 1.475 TPH																									
Green Belt Development	Green belt area (Acre.): 20 Existing + 12 Proposed Number and species of trees to be planted : 6000																									
Details of Pollution Control Systems:	<table border="1"> <thead> <tr> <th>Sr. No.</th> <th></th> <th>Existing pollution control system</th> <th>Proposed to be installed</th> </tr> </thead> <tbody> <tr> <td>1</td> <td>Air</td> <td>--</td> <td>ESP</td> </tr> <tr> <td>2</td> <td>Water</td> <td>--</td> <td>ETP</td> </tr> <tr> <td>3</td> <td>Noise</td> <td>--</td> <td>Acoustic Enclosures will be provided</td> </tr> <tr> <td>4</td> <td>Solid Waste</td> <td>--</td> <td>It will be used in bio-composting</td> </tr> </tbody> </table>						Sr. No.		Existing pollution control system	Proposed to be installed	1	Air	--	ESP	2	Water	--	ETP	3	Noise	--	Acoustic Enclosures will be provided	4	Solid Waste	--	It will be used in bio-composting
Sr. No.		Existing pollution control system	Proposed to be installed																							
1	Air	--	ESP																							
2	Water	--	ETP																							
3	Noise	--	Acoustic Enclosures will be provided																							
4	Solid Waste	--	It will be used in bio-composting																							
Environmental Management plan Budgetary Allocation	Capital cost (With break up): 280 Lakhs O&M cost (With break up): 39 Lakhs <table border="1"> <thead> <tr> <th>Sr. No.</th> <th>Name of Activity</th> <th>Capital Cost (Rs.Lakhs)</th> <th>Recurring Cost (Rs. Lakhs)</th> </tr> </thead> <tbody> <tr> <td></td> <td></td> <td></td> <td></td> </tr> </tbody> </table>						Sr. No.	Name of Activity	Capital Cost (Rs.Lakhs)	Recurring Cost (Rs. Lakhs)																
Sr. No.	Name of Activity	Capital Cost (Rs.Lakhs)	Recurring Cost (Rs. Lakhs)																							

1	Air Pollution Control System	200.00	12.00
2	Water pollution control systems (E.T.P)	---	15
5	Noise pollution control	20.00	2.00
6	Green Belt Development/ Maintenances	25.00	2.50
7	Environmental monitoring / Environmental Management	25.00	5.00
8	Occupational health & safety	10.00	5.00
TOTAL		280.00	29.0

3. The proposal has been considered by SEIAA in its 63rd meeting decided to accord environmental clearance to the said project under the provisions of Environment Impact Assessment Notification, 2006 subject to implementation of the following terms and conditions:

- empty*
- (i) No additional land shall be used /acquired for any activity of the project without obtaining proper permission.
- (ii) For controlling fugitive natural dust, regular sprinkling of water & wind shields at appropriate distances in vulnerable areas of the plant shall be ensured.
- (iii) Regular monitoring of the air quality, including SPM & SO₂ levels both in work zone and ambient air shall be carried out in and around the power plant and records shall be maintained. The location of monitoring stations and frequency of monitoring shall be decided in consultation with Maharashtra Pollution Control Board (MPCB) & submit report accordingly to MPCB.
- (iv) Necessary arrangement shall be made to adequate safety and ventilation/arrangement in furnace area.
- (v) Proper Housekeeping programmes shall be implemented.
- (vi) In the event of the failure of any pollution control system adopted by the unit, the unit shall be immediately put out of operation and shall not be restarted until the desired efficiency has been achieved.
- (vii) A stack of adequate height based on DG set capacity shall be provided for control and dispersion of pollutant from DG set. (If applicable)
- (viii) A detailed scheme for rainwater harvesting shall be prepared and implemented to recharge ground water.
- (ix) Arrangement shall be made that effluent and storm water does not get mixed.
- (x) Periodic monitoring of ground water shall be undertaken and results analyzed to ascertain any change in the quality of water. Results shall be regularly submitted to the Maharashtra Pollution Control Board.
- (xi) Leq of Noise level shall be maintained as per standards. For people working in the high noise area, requisite personal protective equipment like earplugs etc. shall be provided.
- (xii) The overall noise levels in and around the plant are shall be kept well within the standards by providing noise control measures including acoustic hoods, silencers, enclosures, etc. on all sources of noise generation. The ambient noise levels shall conform to the standards prescribed under Environment (Protection) Act, 1986 Rules, 1989.

- (xiii) Green belt shall be developed & maintained around the plant periphery. Green Belt Development shall be carried out considering CPCB guidelines including selection of plant species and in consultation with the local DFO/ Agriculture Dept.
- (xiv) Adequate safety measures shall be provided to limit the risk zone within the plant boundary, in case of an accident. Leak detection devices shall also be installed at strategic places for early detection and warning.
- (xv) Occupational health surveillance of the workers shall be done on a regular basis and record maintained as per Factories Act.
- (xvi) The company shall make the arrangement for protection of possible fire hazards during manufacturing process in material handling.
- (xvii) The project authorities must strictly comply with the rules and regulations with regard to handling and disposal of hazardous wastes in accordance with the Hazardous Waste (Management and Handling) Rules, 2003 (amended). Authorization from the MPCB shall be obtained for collections/treatment/storage/disposal of hazardous wastes.
- (xviii) The company shall undertake following Waste Minimization Measures :
 - Metering of quantities of active ingredients to minimize waste.
 - Reuse of by- products from the process as raw materials or as raw material substitutes in other process.
 - Maximizing Recoveries.
 - Use of automated material transfer system to minimize spillage.
- (xix) Regular mock drills for the on-site emergency management plan shall be carried out. Implementation of changes / improvements required, if any, in the on-site management plan shall be ensured.
- (xx) A separate environment management cell with qualified staff shall be set up for implementation of the stipulated environmental safeguards.
- (xxi) Transportation of ash will be through closed containers and all measures should be taken to prevent spilling of the ash.
- (xxii) Separate silos will be provided for collecting and storing bottom ash and fly ash.
- (xxiii) Separate funds shall be allocated for implementation of environmental protection measures/EMP along with item-wise breaks-up. These cost shall be included as part of the project cost. The funds earmarked for the environment protection measures shall not be diverted for other purposes and year-wise expenditure should reported to the MPCB & this department
- (xxiv) The project management shall advertise at least in two local newspapers widely circulated in the region around the project, one of which shall be in the marathi language of the local concerned within seven days of issue of this letter, informing that the project has been accorded environmental clearance and copies of clearance letter are available with the Maharashtra Pollution Control Board and may also be seen at Website at <http://ec.maharashtra.gov.in>
- (xxv) Project management should submit half yearly compliance reports in respect of the stipulated prior environment clearance terms and conditions in hard & soft copies to the MPCB & this department, on 1st June & 1st December of each calendar year.
- (xxvi) A copy of the clearance letter shall be sent by proponent to the concerned Municipal Corporation and the local NGO, if any, from whom suggestions/representations, if any, were received while processing the proposal. The clearance letter shall also be put on the website of the Company by the proponent.
- (xxvii) The proponent shall upload the status of compliance of the stipulated EC conditions, including results of monitored data on their website and shall update the same periodically. It shall simultaneously be sent to the Regional Office of MoEF, the respective Zonal Office of CPCB and the SPCB. The criteria pollutant levels namely; SPM, RSPM, SO₂, NOx (ambient levels as well as stack emissions) or critical sectoral

Dup
Urgent

parameters, indicated for the project shall be monitored and displayed at a convenient location near the main gate of the company in the public domain.

(xxviii) Six monthly monitoring reports should be submitted to the Regional office MoEF, Bhopal with copy to this department and MPCB.

(xxix) The environmental statement for each financial year ending 31st March in Form-V as is mandated to be submitted by the project proponent to the concerned State Pollution Control Board as prescribed under the Environment (Protection) Rules, 1986, as amended subsequently, shall also be put on the website of the company along with the status of compliance of EC conditions and shall also be sent to the respective Regional Offices of MoEF by e-mail.

(xxx) The environmental clearance is being issued without prejudice to the court case pending in the court of law and it does not mean that project proponent has not violated any environmental laws in the past and whatever decision of the Hon'ble court will be binding on the project proponent. Hence this clearance does not give immunity to the project proponent in the case filed against him.

4. The environmental clearance is being issued without prejudice to the action initiated under EP Act or any court case pending in the court of law and it does not mean that project proponent has not violated any environmental laws in the past and whatever decision under EP Act or of the Hon'ble court will be binding on the project proponent. Hence this clearance does not give immunity to the project proponent in the case filed against him, if any or action initiated under EP Act.

5. The Environment department reserves the right to revoke the clearance if conditions stipulated are not implemented to the satisfaction of the department or for that matter, for any other administrative reason.

6. **Validity of Environment Clearance:** The environmental clearance accorded shall be valid for a period of 5 years to start of production operations.

7. In case of any deviation or alteration in the project proposed from those submitted to this department for clearance, a fresh reference should be made to the department to assess the adequacy of the condition(s) imposed and to incorporate additional environmental protection measures required, if any.

8. The above stipulations would be enforced among others under the Water (Prevention and Control of Pollution) Act, 1974, the Air (Prevention and Control of Pollution) Act, 1981, the Environment (Protection) Act, 1986 and rules there under, Hazardous Wastes (Management and Handling) Rules, 1989 and its amendments, the public Liability Insurance Act, 1991 and its amendments.

9. Any appeal against this environmental clearance shall lie with the National Green Tribunal, Van Vigyan Bhawan, Sec- 5, R.K. Puram, New Dehli - 110 022, if preferred, within 30 days as prescribed under Section 16 of the National Green Tribunal Act, 2010

(R.A. Rajeev)
Principal Secretary,
Environment department &
MS, SEIAA

Copy to:

1. Shri. R. C. Joshi, IAS (Retd.), Chairman, SEIAA, Flat No. 26, Belvedere, Bhulabhai desai road, Breach candy, Mumbai- 400026.
2. Shri. Dr. S. Devotta, Chairman, SEAC, T2/302 Sky City, Vanagaram -Ambattur Road, Chennai -600 095

3. Member Secretary, Maharashtra Pollution Control Board, with request to display a copy of the clearance.
4. The CCF, Regional Office, Ministry of Environment and Forest (Regional Office, Western Region, Kendriya Paryavaran Bhavan, Link Road No- 3, E-5, Ravi-Shankar Nagar, Bhopal- 462 016), (MP).
5. Regional Office, MPCB, Pune.
6. Commissioner, Pune Municipal Corporation, Pune.
7. Collector, Pune.
8. IA- Division, Monitoring Cell, MoEF, Paryavaran Bhavan, CGO Complex, Lodhi Road, New Delhi-110003.
9. Director (TC-1), Dy. Secretary (TC-2), Scientist-1, Environment department.
10. Select file (TC-3).

(EC Uploaded on - 22.07.14)